

# ACCESSIBILITY CODE FOR EDUCATIONAL INSTITUTIONS

ACCESSIBILITY INDIA CAMPAIGN  
CBSE BOARD, INDIA



## (Accessibility Code for Educational Institutions)

*Report of the Expert Committee constituted by Ministry of Education, Government of India, to ensure that all the educational buildings such as pre-primary up-to primary schools, primary up-to upper primary schools, upper primary up-to secondary schools, secondary up-to senior secondary schools, KGBVs, Residential School, hostels, SCERTs, DIETs, BIETs, SIETs etc. have barrier free access*

The Department of School Education & Literacy has been entrusted with the task of preparing customized guidelines and time bound action plan to ensure that all the educational buildings such as pre-primary up-to primary schools, primary up-to upper primary schools, upper primary up-to secondary schools, secondary up-to senior secondary schools, KGBVs, Residential School, hostels, SCERTs, DIETs, BIETs, SIETs etc. have barrier free access.

Accordingly, to prepare customized guidelines for Barrier Free access of Educational Institutes, an Expert Committee under the Chairmanship of Chairman CBSE was constituted and notified vide the Ministry's letter No. F.No.16/2025RMSA-II/IS-18(Part-II) dated 7th January 2021 with the following as members of the Committee:

1. Chairman, CBSE
2. Commissioner, KVS
3. Commissioner, NVS
4. Chairperson NIOS
5. State Project Directors of Uttar Pradesh, Bihar, Gujarat, Assam, Tamil Nadu, Madhya Pradesh, Uttarakhand and Himachal Pradesh
6. Special Invitees to be nominated by the Chairman.

The following experts were subsequently nominated as Special Invitees to the Committee by the Chairman:

1. Dr. Anjlee Agarwal, Co-Founder, Samarthyam
2. Dr. Indumathi Rao, Founder & Regional Advisor, CBR Network
3. Ms. Sudha Acharya, Principal, ITL Public School, Dwarka
4. Ms. Harpreet Kaur, Principal, Sri Guru Harkrishan, Model School, Chandigarh
5. Dr. Aarti Bakshi, Counsellor, Pathways School Noida
6. Dr Vasanthi Thiagrajan, Sr Principal, Sikshya School, Krishnagiri, Tamil Nadu
7. Dr. Sandeep Kumar Jain, JS(Trng.), Central Board of Secondary Education
8. Dr Pragya Verma, DS, Central Board of Secondary Education.

The Committee, after due deliberation, submitted its report to the Ministry of Education, Government of India, on 26th July 2021.

Chairman, CBSE

Commissioner, KVS

Commissioner, NVS

Chairperson, NIOS

State Project Directors of Uttar Pradesh, Bihar, Gujarat, Assam, Tamil Nadu, Madhya Pradesh, Uttarakhand and Himachal Pradesh

Ms. Ritu Singh Sharma, IRS-IT

### **Special Invitees:**

1. Dr. Joseph Emmanuel, Director (Academics), Central Board of Secondary Education
2. Sh. Sanjib Das, Joint Secretary (A&L), Central Board of Secondary Education
3. Dr. Sandeep Kumar Jain, JS(Trng.), Central Board of Secondary Education
4. Dr Pragya Verma, DS, Central Board of Secondary Education
5. Dr. Anjlee Agarwal, Co-Founder, Samarthyam
6. Dr. Indumathi Rao, Founder & Regional Advisor, CBR Network
7. Ms. Sudha Acharya, Principal, ITL Public School, Dwarka
8. Ms. Harpreet Kaur, Principal, Sri Guru Harkrishan, Model School, Chandigarh
9. Dr. Aarti Bakshi, Counsellor, Pathways School Noida
10. Dr Vasanthi Thiagrajan, Sr Principal, Sikshya School, Krishnagiri, Tamil Nadu

## Table of Contents

<b>1. CHAPTER 1: CURRENT SITUATION .....</b>	<b>5</b>
NEED FOR THE CODE .....	6
ABOUT THE CODE .....	7
<b>2. CHAPTER 2: DEFINING STAKEHOLDERS .....</b>	<b>8</b>
PARENTS AND CAREGIVERS .....	9
SCHOOL ADMINISTRATION .....	9
SCHOOL MANAGEMENT COMMITTEE .....	9
<b>3. CHAPTER 3: BARRIERS AND IDENTIFICATION OF BARRIERS.....</b>	<b>Error! Bookmark not defined.</b>
TYPES OF BARRIERS .....	12
DISABILITY SPECIFIC BARRIERS AND ACCESS NEEDS .....	14
<b>4. CHAPTER 4: COMMON BARRIERS IN EXISTING SCHOOLS &amp; EDUCATIONAL INSITUIONS.....</b>	<b>18</b>
INTRODUCTION.....	19
ROAD SAFETY.....	19
APPROACH.....	19
RAMP .....	20
STEPS & STAIRS .....	20
VISUAL CONTRAST .....	21
GENERAL TOILETS .....	21
ACCESSIBLE TOILETS.....	22
CLASSROOMS .....	23
FURNITURE .....	24
FLOORING.....	24
DRINKING WATER UNIT .....	24

ILLUMINATION .....	24
PLAYGROUND .....	25
EMERGENCY EVACUATION .....	25
<b>5. CHAPTER 5: ACCESSIBILITY STANDARDS .....</b>	<b>26</b>
NON-NEGOTIABLE STANDARDS FOR EXISTING BUILDINGS .....	27
ACCESSIBILITY STANDARDS FOR ALL UPCOMING AND NEW CONSTRUCTION .....	28
<b>6. CHAPTER 6: HOSTEL .....</b>	<b>666</b>
ENTRY & EXIT .....	67
ACCESSIBLE ROOM .....	67
CANTEEN/ DINING HALL .....	69
ACCESSIBLE BATHROOM .....	70
BATHROOMS-SHOWER CUBICLES .....	71
<b>7. CHAPTER 7: EMERGENCY EVACUATION IN SCHOOLS AND HOSTELS .....</b>	<b>73</b>
<b>8. CHAPTER 8: INFORMATION AND COMMUNICATION ACCESSIBILITY .....</b>	<b>76</b>
Barriers and Identification of Barriers .....	77
Accessibility Standards .....	78
<b>9. ANNEXURE I .....</b>	<b>80</b>
<b>10. ANNEXURE II .....</b>	<b>104</b>
<b>11. Glossary .....</b>	<b>107</b>
<b>12. References .....</b>	<b>110</b>

# CHAPTER 1: CURRENT SITUATION



Every child has the right to education and opportunities for participation in age-appropriate activities. Education prepares children to lead a productive life and fulfill their role as useful members of the society. It is therefore imperative that provisions for all children to attend schools are created and efforts are made to identify and remove barriers. It is equally important to safeguard the rights of children with disabilities if the goal of 'Education for All' is to be achieved. An accessible, barrier-free environment benefits all, not just children with disabilities.

Right to Education Act, 2009 provides every child with equal rights and opportunities to access educational services irrespective of child's class, caste, race, gender, geographical origin, and abilities. The Right of Persons with Disabilities (RPwD) Act, 2016 aims to provide equal opportunities to children with disabilities and emphasizes access to public buildings (both government & private). The National Education Policy (NEP) 2020 reiterates the need for barrier-free access to children with special needs for providing equitable educational opportunities.

## **1.1. NEED FOR THE CODE**

This Code examines the physical barriers and information & communication barriers of access to school facilities for children with disabilities. It also provides in detail cross disabilities and child friendly standards with cost effective solutions for existing buildings, as well as all-encompassing elements to make new buildings compliant with national accessibility standards. Experience from research, access audits of schools both in rural and urban settings, trainings and user group inputs is the foundation of the Code. Essential and non-negotiable universal design elements are provided with easy-to-understand line drawings, illustrations and photos of best practices for all those who advocate for and implement an accessible environment and helps facilitate finding the right answers or solutions for even the most complex issues.

According to UNCPRD, "Reasonable Accommodation" means necessary and appropriate modification and adjustments without imposing a disproportionate or undue burden, where needed, to ensure that Persons with Disabilities enjoy and exercise on an equal basis fundamental human rights and freedom. India, being a signatory to UNCPRD, is committed to ensure access to Persons with Disabilities on an equal basis with others, with regard to physical environment, transportation, information & communication technologies and systems, and other facilities and services.



Most people understand accessibility only in terms of ramps, lifts, elevators and toilets for Children with Disabilities. However, accessibility is a much broader term, which encompasses the attitude of acceptance and a commitment to providing a welcoming environment, both in terms of suitable infrastructure and a conducive environment for learning. It puts the onus on the school management and administration to lay down policies, build structures, procure material and equipment as well as to maintain flexibility in the approach to modify and adapt the existing systems to cater to children with a wide range of disabilities and unique needs. Accessibility need not mean only physical access, but access to information in various accessible formats, school websites, brochures, bulletins, teaching-learning material both in offline and online formats, signage and directions to navigate the school campus and various facilities.

## 1.2. ABOUT THE CODE

Accessible environment refers to promotion and implementation of universal access standards and codes in the environment built for all children and adults in and around schools. This is particularly relevant in the context of Children with Special Needs (CwSN); referred as Children with Disabilities (CwDs) in this Code. CwDs are those having locomotor impairments, visual impairments, speech & hearing impairments, intellectual & learning disabilities; as well as those with developmental disabilities viz. cerebral palsy, autism, mental retardation and multiple disabilities. Accessible environment also benefits teaching and non-teaching staff of schools, parents and visitors. The code focus on identifying obstacles and barriers in the physical infrastructure (indoor & outdoor facilities) and in the communication & learning ecosystem of educational institutions and offers cost effective solutions for the same. The code is discussed below as follows:

- Highlights the need for inclusive environment in schools, convergence of communication & universal design in learning and defining stakeholders;
- Provides in-depth information on the national physical infrastructure accessibility standards for schools and educational institutions. The physical accessibility standards in the Code are referred from the National Building Code 2016, Harmonized Guidelines and Space Standards for Persons with Disabilities, 2016 and Indian Roads Congress, Guidelines for Pedestrian Facilities, 'IRC 103: 2012'. Universal Design principles are applied to provide solutions for children with cross disabilities. Experience from research, access audits and user group inputs are the foundation of this Code. The images and graphic illustrations are provided by Samarthyam, a Disabled Persons Organization, from access audits of schools in 16 states under the Inclusive Education Project and Accessible India Campaign, as well as from the best practices from India.

# CHAPTER 2: DEFINING STAKEHOLDERS



Inclusive school education demands mutually sustaining relationships between schools and their surrounding communities. Under the RTE Act, 2009, specific provisions have been made for democratisation of schools, involving parents and local communities in school education. In the form of School Management Committees (SMC), they have been entrusted with certain statutory powers to play their due roles in shaping and running the schools. SMCs are responsible for their own school— its efficiency and quality of teaching and learning.

### **2.1. PARENTS AND CAREGIVERS**

Often it is the caregivers who bear the major burden by assisting for daily needs of Persons with Disabilities, apart from providing financial and social supports to their dependent persons with disabilities. In the process of caregiving, they may have to forego their opportunities to attend work of their choice, earn money, progress in their career, live a satisfactory social life, and to even spend time leisurely. Accessible educational institutions take off the extra burden to care for the child/adult when they are out of home.

### **2.2. SCHOOL ADMINISTRATION**

The journey of inclusion indicates a process rather than an event; the process reflecting occurrence of significant changes brought about by new ways of thinking, new ways of operating in the classroom and adapting to the constant change in thinking, attitudes, and social conditions. Educational administrators should take the responsibility for setting and monitoring the overall standard of the service and ensure appropriate management structures for the same.

### **2.3. SCHOOL MANAGEMENT COMMITTEE**

School Management Committee (SMC) members are now a vital agency, who have a conclusive role in monitoring the working of an inclusive school; preparing and recommending school development plans, monitoring the utilisation of grants, and making an atmosphere where the home and the school share the responsibility of educating the child. The members of SMCs are required to be oriented, trained and supported for their effective participation in school related activities and in performing their expected roles to actualize the goals of the RTE Act, 2009. It is imperative to equip them with certain skills like identifying the needs of inclusive schools, analyzing them, developing plans of action and interventions as per the standard and norms set in the RTE Act.

<http://scertdelhi.nic.in/>

Role	What Can I Do	How Can I Do
Training - Understand roles and responsibilities and the tasks before them.	Creating confidence - They are capable of bringing change in their schools and monitor construction.	Understand unique role of teachers and building alliance with the teachers to change schools.
Setting-up a mechanism and process of access audit of the various elements in school	Form a group of members for access audits and use self-assessment checklist Section 8.4.1. Payment terms should carry mandatory compliance clause.	If required, get training from local NGOs on basic access needs of CwDs as given in section 3.2.
Provision of accessible transportation- For children with severe and multiple Disabilities	Adaptations in educational institutions and public vehicles to ensure accessibility of children using mobility aids like wheelchair users/ crutch users, etc.	In consultation with local civil society organizations of persons with disabilities and disability experts, adaptations in locally available public vehicles can be worked out.

# CHAPTER 3: BARRIERS AND IDENTIFICATION OF BARRIERS



A barrier is defined as “anything that prevents a person with a disability from fully participating in all aspects of society because of his or her disability”. In other words, barriers occur when places and activities that all people should have access to, are designed in ways that limit such access. Barriers limit activities that people with disabilities can do, the places they can go, or the attitudes of others toward them. For example, heavy doors are barriers for people with limited upper body movement. These types of doors prevent people from entering and using building elements.

### 3.1. TYPES OF BARRIERS

There are various types of barriers prevalent in the schools that hinder CwDs the access to education and inclusion. Some common barriers are as follows:

#### **Social stigma and attitude linked with disability**

- Stereotypes linked to disability lead to negative attitude towards Children with Disability and their education. Parents, teachers and School Management often ignore the rights and needs of children with disability, which results in their discrimination and exclusion.

#### **Barriers to access information and educational material**

- In many schools, educational material and teaching methods remains inaccessible for children with sensory impairment (visual, speech and hearing), learning and other developmental disabilities. Accessible teaching & learning material and methodologies should be provided to CwDs in inclusive setups.

#### **Barriers to access physical infrastructure**

- Inaccessible and faulty designs create physical /architectural barriers for CwDs and hamper their accessibility to schools

#### **Barriers faced by girls with disabilities**

- Access to education for girls with disabilities is limited, owing to prejudice & discriminatory attitudes that encourage girls to stay in domestic roles, and therefore deem their education unnecessary.
- Lack of appropriate sanitation facilities in schools results in menstruation being a regular interruption to girls’ education.
- Safety concerns and fear of inadequate protection from sexual violence.

- In some regions, not all girls are registered at birth, making school enrollment impossible.

**For girls with disabilities**, these barriers are exponentially worse. Families' expectations for them are even lower and investing in their education is often seen as a waste. The shame surrounding disability sometimes results in girls being hidden at home. If financial resources are limited, disabled boys' education is largely prioritized, since males are more often expected to work and provide income in the future, regardless of disability. If a child's mobility or vision is impaired, transportation to school poses another challenge. There are generally more investments in appliances for boys than girls like crutches or wheelchairs.

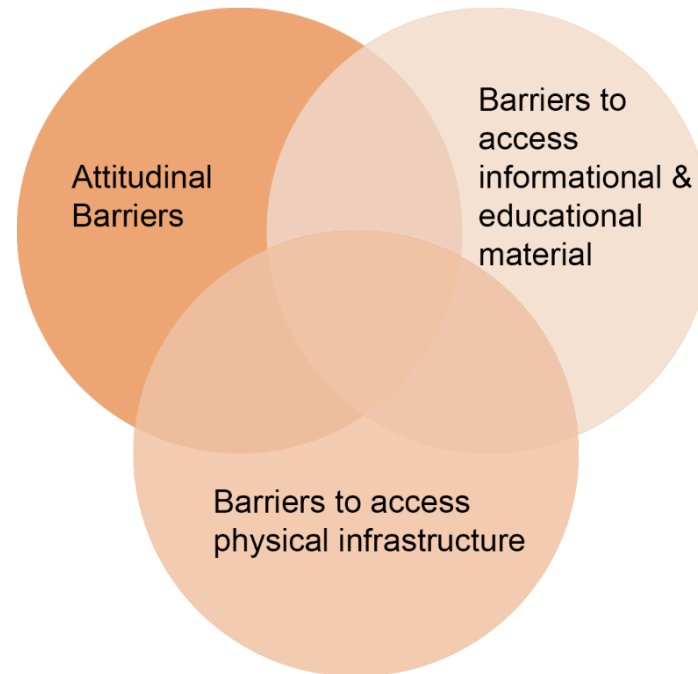

**Same gender accompaniment to toilet:** Another concern is the caregiver accompanying a girl to the bathroom has to be of the same gender. Sometimes, the toilet doors are missing or broken, or have missing or broken door latches, or be missing a roof, having inadequate or lack of illumination, or distance of toilet blocks from the classroom block is too much. All these factors may lead to concerns regarding access, safety and evacuation. Lack of running piped water, facility for proper disposal of menstrual pads/cloth, lack of incinerators and inaccessible toilet designs could pose a great challenge to girls and women with disabilities. In most cultures, taboos and superstitions associated with menstruation severely impacts the participation of women in social, religious, economic and educational activities often times leading to girl children dropping out of school. These problems

multiply exponentially in case of girls/women with physical disabilities, visual and cognitive impairment.

### 3.2. DISABILITY SPECIFIC BARRIERS AND ACCESS NEEDS<sup>1</sup>

#### For children with loco-motor disabilities and Cerebral Palsy

- Ensure wheelchair accessibility to classrooms, toilets, office rooms, playground, etc.
- The prescribed gradient of the ramp -1:15 should be strictly adhered to and all ramps should be fitted with handrails.
- Aids and appliances like calipers, wheelchairs, braces, special chairs, crutches, wedges, pencil grips, communication boards, etc. should be made available.
- Ensure adequate space allocation to meet individual needs of children using assistive devices
- Ensure proper positioning and safe/careful handling of children with cerebral palsy, with the help of the resource teacher/parent
- All classes and teaching facilities for these children should be provided on the ground floor.
- Arrange for a suitable writer for children with writing difficulties.
- Ensure enough response time to children with cerebral palsy. This is important as they might have communication and speech problems.

#### For children with Hearing Impairments

Since language and communication is the major barrier for this group of children, the following needs to be emphasized:

- Provision of suitable hearing aids and their maintenance should be ensured.
- The resource teacher should provide auditory training to make optimum use of the residual hearing of the child.
- Seating of the child should be such that s/he gets a clear view of the teacher's face (for lip reading) as well as the black board.

---

<sup>1</sup> These are just guidelines for the States to help them develop some mechanism to provide barrier free access to children with special needs. However, these may be adapted/ modified according to the individual needs of the child.



- Ensure increased use of pictorial teaching learning materials.
- Level of difficulty of language needs to be adapted as per the comprehension level of the child.
- Ensure use of Indian Sign Language with the help of the resource teacher, if required.
- Children with language acquisition problems should be exempted from the 3-language formula. Sign Language can be used as an option.
- Sign language can be given as an option under co-curricular activity to enhance peer support.
- Assessment procedures may include objective type questions, instead of essay type questions for children with difficulties in language acquisition.
- Extra response time needs to be provided, wherever necessary.
- Children with language difficulties should be exposed to language acquisition and reading software.

#### **For children with Visual Impairments**

- Ensure availability of accessible teaching learning material (Braille, large print, audio, e-text, etc.).
- Making science labs accessible by Braille labeling, tactile charts/ diagrams.
- Ensure increased use of verbal instructions/ directions while teaching.
- Ensure availability and use of embossed and tactile TLM (maps, globes, charts, models, diagrams, etc).
- Availability, training and use of aids and appliances (Braille, Taylor frame, white cane, abacus, low vision aids, magnifiers, etc.) should be ensured.
- Availability and training in screen-reading and scanning software should be done.
- Training in daily living skills, orientation & mobility (like-human guide technique) must be provided to children with seeing difficulties, as per the needs.
- Ensure effective orientation of children with visual impairments in school environment with active involvement of peers.
- Proper training to be imparted to children with low vision in making optimum use of residual vision with the help of resource teacher.

- The school environment including the pathways/walkways should be illuminated, safe and free of all obstructions.
- Warning strips/ textures to be provided before the beginning of steps/ kerbs etc. so that children with visual impairment do not have an accidental fall.
- Seating of a child with low vision should be such that s/he gets a clear view of teacher's face as well as the black board.

### **For children with Autism Spectrum Disorder (ASD)**

- Clear signage makes it easier for them to get about quickly and efficiently. When anxious or stressed, they find it easier to process pictorial signage rather than written ones.
- Because of the varied ways that individuals process sensory information, some individuals with autism are more comfortable with floor, i.e., Indian style toilets, while others with commodes. Hence, both options need to be provided.
- Because of visual processing issues, there should be handrails on the inner (wall) side where staircases are flanked by a wall on one side and a drop on the other.
- Some individuals with ASD may be inveterate climbers and some others tend to wander off and sometimes get lost, therefore, there should be grills or other preventive arrangements on windows and on boundary walls
- Functions of areas should be given visual clarity to provide predictability and reduce anxiety which is necessary for individuals with ASD.
- Clear indications of areas of study, work, eating, recreation etc. may be provided. In schools where the same area is used for different activities at different times, visual indicators can be used.

### **For children with Intellectual Impairments**

Since this section mainly focuses on adaptation in teaching learning processes, the following need to be emphasized:

- Ensure that visual, tactile and pictorial learning aids are available and accessible.
- Level of difficulty of both language and content need to adapt as per the comprehension level of the child.
- Use of concrete objects as TLM, needs to be emphasized.
- Enough time for individualized teaching learning opportunities.

- Based on the child's level of understanding, the content and evaluation should be adapted. (For example-numbers of concepts taught could be reduced if required; questions could mainly be multiple choices/ fill in the blanks, etc).

### **For children with Multiple Disabilities and High Support Needs**

- Availability, training and use of appropriate aids and appliances should be ensured.
- Access to communication and information in the required language through interpreters, electronic devices, etc. should be ensured.
- Information to be provided in appropriate format (Braille, sign language, e-text, large print, tactile, audio-visual, etc).
- Teaching needs to be more application oriented, experiential and practical for this group of children.
- Training in mobility and daily living skills should be provided with support of resource teacher/ parents/ peers.
- Effective use of peer support to enhance communication and mobility skills.
- Use of appropriate technology, technological aids and software, like PacMate for deaf-blind children, should be encouraged.

# **CHAPTER 4: COMMON BARRIERS IN EXISTING SCHOOLS & EDUCATIONAL INSTITUTIONS**



## 4.1. INTRODUCTION

This section focuses on the physical accessibility barriers in existing schools and suggests probable solutions. The existing buildings pose a unique challenge that requires us to work within the existing structures. Some of the areas for school accessibility and school improvement are highlighted in this section. Efforts should be made to fulfill the standard compliance norms of barrier-free access and reasonable accommodation for CwDs to enable them to access school-services & facilities.

## 4.2. ROAD SAFETY

- Schools on the main roads/ busy arterial roads usually face high traffic and vehicular movement.
- This results in accidental hazards for both non-disabled children as well as CwDs.
- Noisy roads pose discomfort to children with hearing impairments.
- Refer **Section 5.2.1** for accessibility standards.

## 4.3. APPROACH

- Approach is usually uneven and unmaintained.
- In most towns and villages there are cow catchers/cattle traps provided at main gate and CwDs using mobility aids cannot move/access the infrastructure independently.
- Children with visual impairments get obstructed and disoriented due to unmaintained approach.
- Collapsible gate channel projections are very commonly found in school buildings. It is a trip hazard for everyone especially for children who have impaired mobility.
- Refer **Section 5.2.1** for accessibility standards.

#### 4.4. RAMP

- Ramps are usually not provided for all facilities. However, even if they are provided, they are blocked, unmaintained or locked due to sheer ignorance/negligence.
- At times, the ramps are found to be permanently blocked by a newly constructed iron grill or have a handrail in the centre.

##### **Ramp gradient and flooring/surface:**

- For children using mobility aids such as wheelchair, crutches, walkers, etc. steep ramps are provided without any standards.
- Slippery tiles or high grooves for friction in flooring are not safe to use.
- Handrail is provided on one side only or in center thereby reducing the effective walking width.
- Ramps provided are through the sand / muddy area, which is extremely difficult to access by wheelchair and crutch users.

##### **Unmaintained and steep ramps:**

- Ramps provided in schools remain unused by Children with Disabilities and are dangerous for other children who might fall over and get hurt.

##### **Regular maintenance:**

- Ramps are often broken, chipped off with uneven surfaces; unsecured handrails and uneven edges, which usually result in accidental hazards.

#### 4.5. STEPS & STAIRS

- Steps and Stairs do not have handrails.
- Usually, a parapet wall is provided on the open side only.

## 4.6. VISUAL CONTRAST

- Children with low vision find it difficult to locate elements, which have similar colour to the surroundings.
- For example, usually similar colour paint is used for the wall doors and door frame. Especially in toilets, white wall and floor tiles are used with white toilet accessories and fittings.

## 4.7. GENERAL TOILETS

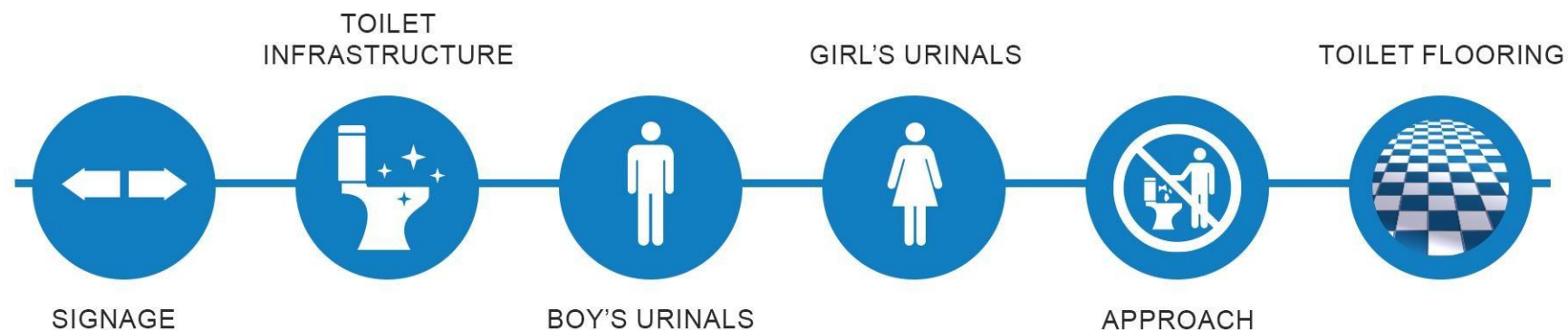

- **Signage**
  - In absence of signage, it sometimes becomes difficult for Children with Disabilities to locate the toilets and moreover to differentiate between male and female toilets.
- **Toilet Infrastructure**
  - In many schools, proper urinals and toilet cubicles are not provided and children are made to urinate and defecate in open and unhealthy conditions.
  - In adverse weather conditions, situations are grim as it is not possible to use toilets which do not have overhead shed and illumination.
  - For Children with Disabilities, it is impossible to use toilets in schools, which do not have a roof and structure, are not maintained with water.

- **Boy's Urinals:**
  - For boys with short stature or with locomotor and visual impairments, high urinal rims are out of reach.
  - Urinals are always marked by a step.
  - Absence of grab bars makes it difficult to use by boys wearing calipers/ using crutches.
- **Girls Urinals:**
  - Majority of the girls either do not go to schools or dropout due to non-availability of toilets. Open defecation results in teasing, harassment and other attitudinal problems.
  - As the toilets are provided at the rear side / or at long distance from the school buildings, the approach is usually not maintained and makes it difficult to use the toilets.
  - For girls, open urinals are provided without partition/urinal shield.
- **Approach:**
  - The way to toilets is usually not maintained, full of filth and garbage, do not have illumination, full of potholes and are unusable during monsoon.
- **Toilet Flooring:**
  - Slippery surface of the washrooms is very dangerous for all children; especially for Children with Disabilities, as it is a slip hazard.
  - Girls' toilets are not provided in many schools hence they are bound to use boys' toilets or defecate in open, resulting in reluctance to go to schools.
  - Toilets are not provided with latches and doors. Sometimes girls go in pairs to use toilets for safety and privacy reasons.

#### 4.8. ACCESSIBLE TOILETS

- Accessible Toilets are usually not provided in the schools. Even if they are provided in some schools, these are not as per standards and are not wheelchair friendly.
- At times, just a western commode seat is provided in a small cubicle of size 900 x 900mm (3ft x 3ft); and instead of grab bars, handles / towel rods are placed which are risky to use by Children with Disabilities.
- For children using wheelchair or other mobility aids, general toilets are not friendly resulting in Children with Disabilities, especially girls, dropping out of schools.



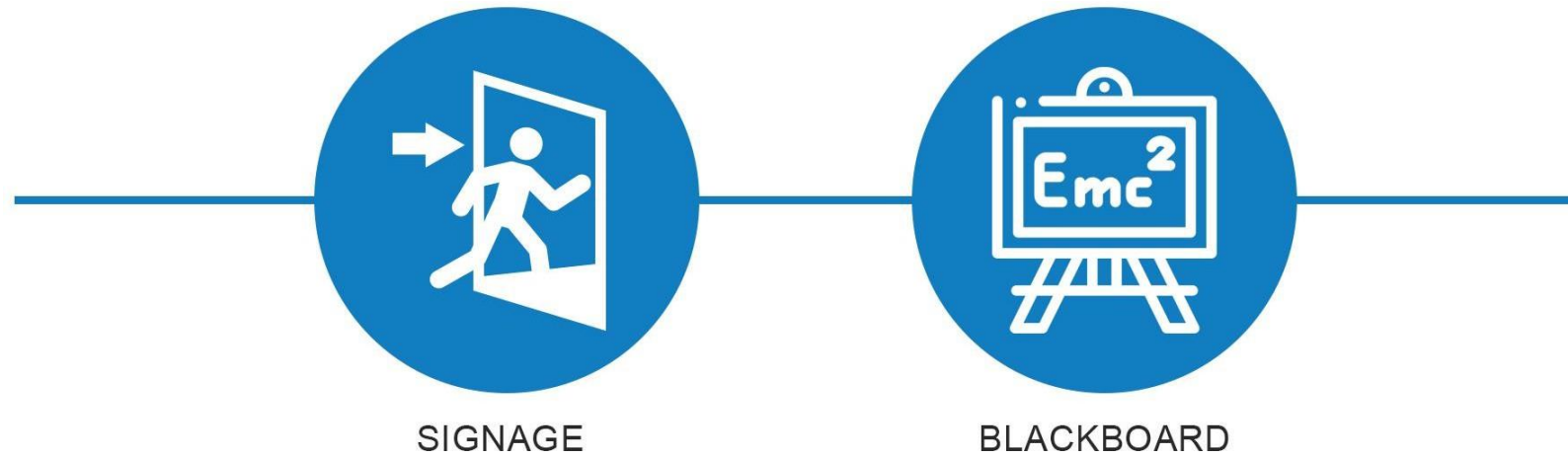

- **Signage:**
  - Absence of signage in the school (within the premises and outside the school) leads to disorientation among the students, newcomers and visitors. For students who have intellectual disability, visual and/or hearing impairments, signage is essential.
- **Blackboard:**
  - If the blackboard is mounted too high, it becomes a hassle for the children with short stature or for those who use wheelchairs.
  - It is also impossible for teachers with short stature to reach high blackboards.

#### **4.10. FURNITURE**

- Classrooms having fixed furniture -seats and tables, are inconvenient for students wearing caliper, crutch users or who are tall.
- Desks are overcrowded due to more than 4-5 children seated in one bench.
- Many children are made to sit on one bench in schools due to space crunch, which is extremely uncomfortable while writing and otherwise.
- High seating desk may work well for secondary school students; however, for primary schools, desks appropriate to their height and built should be provided.

#### **4.11. FLOORING**

- Slippery and glossy finished floor is dangerous for the children especially with visual or locomotor impairments.

#### **4.12. DRINKING WATER UNIT**

- Taps are provided too high and cannot be accessed by small children and wheelchair users.
- For children using other mobility aids such as crutches, calipers, walkers, etc. it is even more difficult and at times impossible.
- Many a times, only taps are provided without any sink/ basin making it inconvenient for children with disabilities to drink water.
- Drinking water unit marked by high platform is inaccessible for small children and children using wheelchair.
- Drainage for spilled water is not provided, resulting in water clogging and slippery flooring.

#### **4.13. ILLUMINATION**

- Low illumination level, not safe for girls (with/without disabilities) and for those with low vision.
- Reading or writing in insufficient light causes stress on the eyes and reduces vision power.
- In classes and general circulation areas of school including toilets, low illumination levels can cause discomfort and is hazardous for children with low vision, girls and female staff.

#### **4.14. PLAYGROUND**

- Playgrounds are usually uneven and unmaintained, which are not friendly for use by children with disabilities.
- Generally, access to the sitting areas/ benches by means of paved pathway is not provided in the playgrounds.
- Ramps are not provided in playgrounds assuming children with disabilities will not play with other children.

#### **4.15. EMERGENCY EVACUATION**

- In many schools, provisions for emergency evacuation are not yet considered. This can result in severe mishaps and accidental hazards at the time of fire, disasters or emergency situations.
- Classrooms are over packed with children (as high as 120 kids in one classroom). It has been experienced that if one child wants to use the washroom s/he will take good amount of time to get out of his/her bench and disturb others at the same time.

# CHAPTER 5: ACCESSIBILITY STANDARDS



For all upcoming, new and existing buildings, these accessibility standards are mandatory. The checklist to be used for self-assessment is given in Annexure I. For some existing school buildings/campus, if all standards cannot be provided, then the non- negotiable standards detailed here shall be provided.

## **5.1. NON-NEGOTIABLE STANDARDS FOR EXISTING BUILDINGS**

Many a times, existing buildings are not accessible for Children with Disabilities. The Rights of Persons with Disabilities Act, 2016 and Accessible India Campaign mandate retrofitting existing school buildings with accessibility elements. These elements are listed in this section and are non-negotiable. The checklist to be used for self-assessment is given in 8.4.1. In addition to these, the SMCs and funding agencies must ensure to achieve accessibility in all areas as given in section 5.2.

1. Safe road crossing elements (**refer section 5.2.1**)
2. Ramp (**refer section 5.2.4**)
3. Stairs and steps (**refer section 5.2.5**)
4. Handrails (**refer section 5.2.6**)
5. Classrooms (**refer section 5.2.17**)
6. General toilets (**refer section 5.2.8**) with Boy's and Gent's staff toilet having one accessible urinal (**refer section 5.2.9**)
7. Accessible toilet (one accessible toilet; if there is space available then separate toilet one for boys and one for girls is preferred) (**refer section 5.2.10**)
8. Library (**refer section 5.2.17**)
9. Laboratory (**refer section 5.2.17**)
10. Midday meal/ canteen (**refer section 5.2.18**)

## 5.2. ACCESSIBILITY STANDARDS FOR ALL UPCOMING AND NEW CONSTRUCTION

### APPROACH TO SCHOOL

- Road safety measures such as road signs, traffic calming, signal crossings, STOP lines and zebra crossing should be provided.
- Traffic signals should have audio beeper and audio announcement systems.
- Approach to the school should be well maintained and leveled surface should be provided.
- Paved flooring provides comfortable access to all students and teachers and benefit children and adults with disabilities.
- The surfaces should be firm and even, with a finish which is slip resistant in all weather conditions.
- Any kerbs in the route should have appropriate drop kerbs to allow access to a wheelchair.
- A strip on the cattle trap which is 1000mm wide can be used to allow children to walk on it **(photo 5.1)**.
- Checkered tiles/ pavers can be used for footpath flooring in rural/towns.
- The path from the gate to the school buildings, playground and toilet must be clear, firm, leveled and regularly maintained.
- Main entrances and doorways in the school buildings should be 1500-1800mm wide.
- Classrooms, toilets, labs etc should have clear door width of 900mm minimum.
- Sharp turns in the walkways should be avoided.
- The walkway must be clear of any hung and protruding obstructions such as windows, lights, low branches, flowerpots and signposts etc.
- A handrail should be provided at any dangerous point in the walkway.
- Guard rails are a must in situations where there is a sudden change in the level including stairs and verandah.
- The ends of the handrails should be rounded off/ grouted in the ground (bent downwards) to avoid injury.
- The height and width of steps should be equal (riser and tread).
- Bright & contrast colour tactile pavers (preferably yellow) should be used at every change in slope, at the beginning and ending of a staircase for easy recognition and at turnings.
- All floor surfaces should be non-slip/ anti-skid/ matt finish and any loose gravel or cobblestones should be avoided.
- Threshold/ channel should either be embedded in the ground or beveled as per the illustration.



Photo 5.1 Cow catchers covered with bridge plate



Photo 5.2 Tabletop with tactile pavers



Photo 5.3 Tabletop with cobble stone on slope and cement concrete surface on top



Photo 5.4 Examples of safety signs around school zone

### **SIGNAGE - WAY FINDING VISUAL AND AUDITORY**

- **External:** should be mounted above 2200mm from the finished floor level for proper head clearance
- **Internal:** should be placed between 1400mm to 1600mm from the finished floor level on the wall
- **International Symbol of Accessibility:** to be displayed for all the accessible services and facilities provided
- **Sign board:** should also contrast with the wall on which it is mounted
  - Surface of the sign should not be reflective
  - Some signs such as those adjacent to or on a toilet door may be embossed so that they can be read by touch



## ROOM SIGNAGE

- Numbers/nameplates etc. to be in Braille & raised alphabets by 1-1.5mm; for adults Braille signage should be placed on wall next to door latch side between 1400mm-1600mm height and for children at 1000mm height from floor level **(Figure 5.5 & Photo 5.6)**
- Signage that has big fonts, colour contrast and are well illuminated benefit everyone, particularly those with low vision.
- Braille plates giving information of facilities etc. shall be provided on the handrails of stairs.
- Way finding signage in vernacular and Braille should be provided at strategic locations.
- Nameplates and numbers of the rooms to be in Braille & raised alphabets, bold & color contrasted with their background **(Photo 5.7)**.
- Contrast-colored symbols/ pictograms to denote or mark different places like living room, storeroom, kitchen, toilet, common rooms, therapy room, etc. should be used.
- Clear indications of eating, sleeping, recreational, work areas, etc. will enable individuals to function, work and live better
- Real objects as pictograms can be used for signage, for example a tap with a tumbler for the drinking water area or a book and pen for a study area

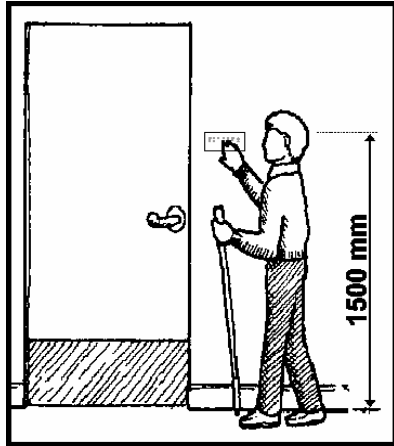

Figure 5.5 Room signage provided towards the latch side of the door



Photo 5.6 Room signage provided towards the latch side of the door

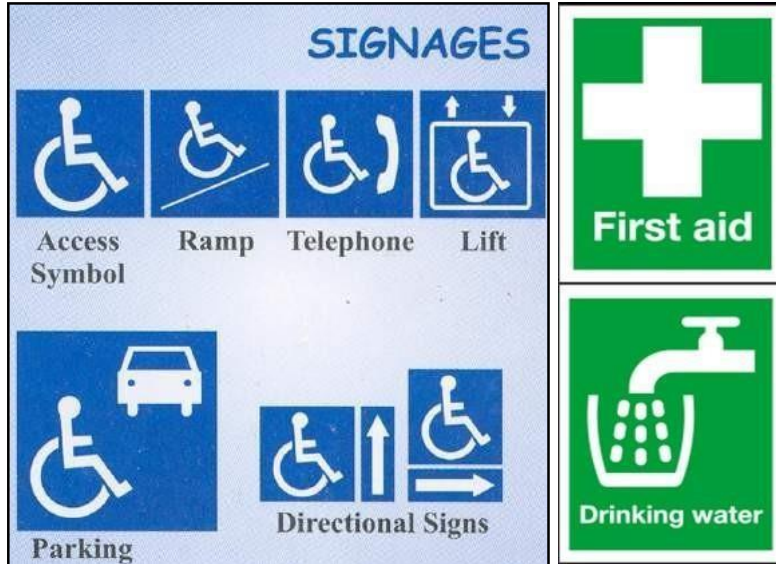

Figure 5.7 Signage with pictogram for accessible elements

- For a multistoried building, key plans of all the floors are to be placed near the main entrance/reception area and also on all the floors in the lift and staircase.
- An illustration with different colors to be given in the key plan (**Photo 5.8**) to help interpret the signage on each level. For example: red color for first floor in the key plan and red color signage at the staircase and/or lift entrance helps in identification of the floor

Ground	<b>G</b>	Ground
1 <sup>st</sup> Floor	<b>1</b>	<b>1<sup>st</sup> Floor</b>
2 <sup>nd</sup> Floor	<b>2</b>	<b>2<sup>nd</sup> Floor</b>
3 <sup>rd</sup> Floor	<b>3</b>	<b>3<sup>rd</sup> Floor</b>
4 <sup>th</sup> Floor	<b>4</b>	<b>4<sup>th</sup> Floor</b>

**Suggested colour coding multi- floor building**

Figure 5.9 Key plans of floors

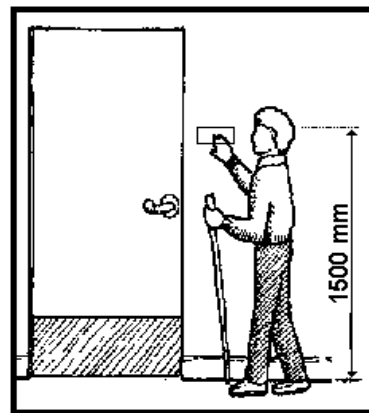

Figure 5.9 Signage with Braille & raised alphabets

## RAMP

- **Gradient:**
  - **Indoor-** Gentle slope of 1:15 max.
  - **Outdoor-** For first floor and above 1:15 or 1:20 gradient ramp is advised depending upon availability of space
- **Width:**
  - 1500mm minimum; 1800mm is preferred
- **Landings:**
  - To be provided for every 750mm of vertical rise.
  - Clear space or size of 1500mm x 1500mm minimum.
  - At the beginning and the end of the ramp and at turnings
  - At intervals of every 9 meters for a gradient of 1:15 or 1:20
- **Handrails:**
  - To be on both sides at two heights- 760mm-900mm, painted in contrast color against the background wall; both ends to be rounded and grouted and extend 300mm beyond top and bottom of ramp **(Figure 5.10)**
  - Surfaces (ramp & landing) should be slip resistant. Grooves on cement ramp not exceeding 5mm or checkered tiles can be provided.
  - Warning tactile paver should be placed at 300mm before and after the ramp edges **(Figure 5.11)**
  - Ramp in the schools should not be obstructed by vehicles and ramp entry should not be kept locked. These incidences are common when step entry is made as common entry.
  - Ramp entry should be used as main entry which benefits everyone - disabled, old and those with reduced mobility.
    - Gradient of the ramp should be maximum 1:12, i.e., for every rise of 1 unit height, length of the ramp should be 12 units maximum. A gentle ramp of 1:15 gradient is preferred as it is easier to maneuver wheelchair on gentle slope.
  - Grooves on ramps should not have height of more than 10mm. CC/ matt finish/ anti-skid tiles such as checkered tiles used on footpaths are good to use for ramp flooring.

- Ramp edges should be flushed with the flooring and the pathway leading to the ramps should be firm and leveled.
- Ramps should be provided on one side of the steps and not in center. L-shape ramps are preferred if the plinth height is more.

**Ramp** with a gradient of 1:12 is found steep by many wheelchair users, while using it independently. Wheelchair users roll backwards on such steep ramps while ascending and lose control during descending which might result in accidental hazards.

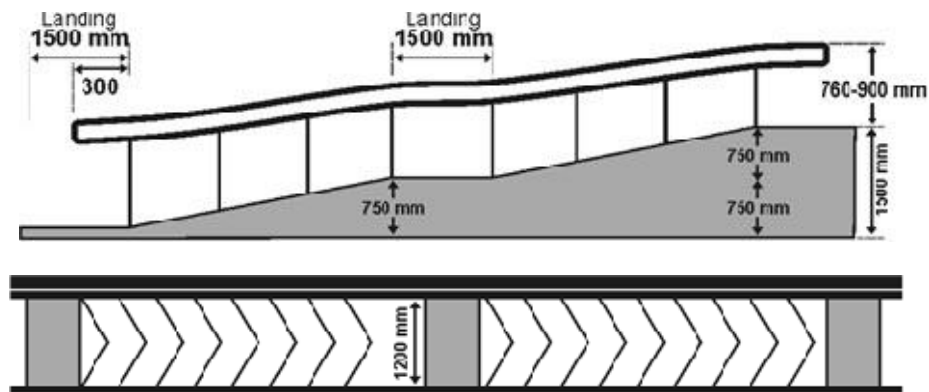

Figure 5.10 Ramp with handrails on both the sides

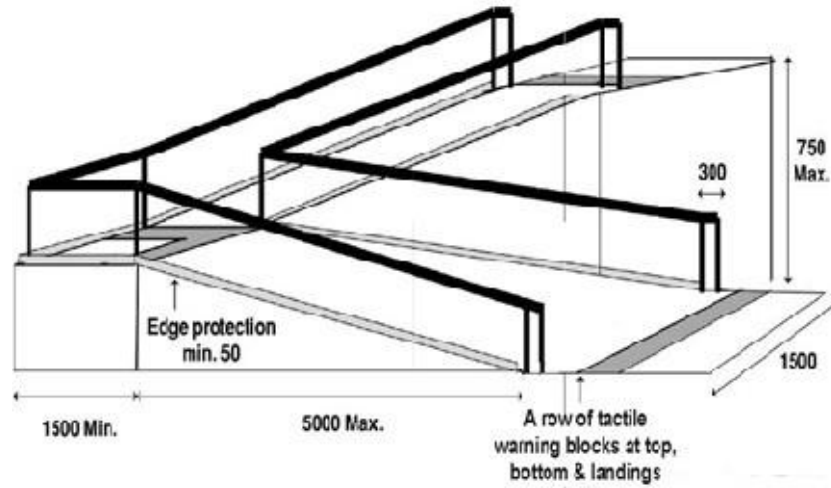
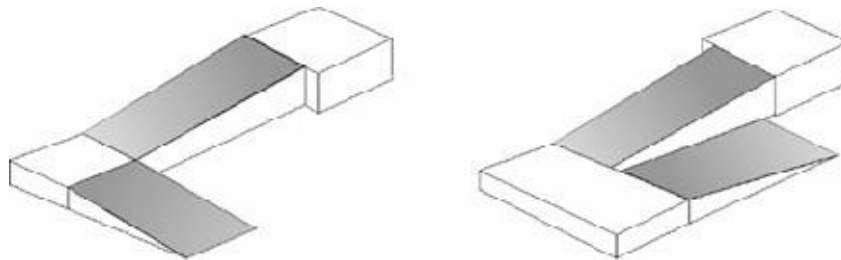

Figure 5.11 L-shape and switch back platform ramps for schools having less space in front for ramp



## STEPS AND STAIRS

- Steps to have equal/uniform:
  - Uniform risers (step height): 150mm maximum
  - Uniform tread (step width): 300mm minimum
- The steps should have an unobstructed width of at least 1200mm
- Landing should be 1200mm deep, clear of any obstruction
- Have continuous handrails on both sides, including the wall (if any) and also on landings
- Handrail height- two levels 760mm and 900mm, painted in contrast color to background wall
- Warning paver to be provided 300mm before the beginning and at the end of all set of steps and at landings
- 50mm wide contrast color band/strip should be provided at the step edge, extending the full width of the step. Landings to also have a row of warning strip **(Photo 5.12)**
- Nosing to be avoided
- Should be adequately and uniformly illuminated with level of illumination between 100-150 lux
- There needs to be signage indicating the floor level on each floor
- It is desirable to use tactile features on the handrail to indicate the end of the rail and to give information for benefit of children with visual impairments (e.g., it is possible to indicate the floor level on each handrail by adopting the use of raised spots, where one spot indicates first floor, two spots indicate second floor etc.)
- Step edges-50mm minimum should have bright contrasting colors, which helps children with low vision to identify height and depth of each step **(Figure 5.13)**
- Soffit- open area under the staircase should be cordoned off by guard rails **(Photo 5.14)**



Photo 5.12 Landings having a row of warning strip



Photo 5.13 Open area under the staircase should be cordoned off

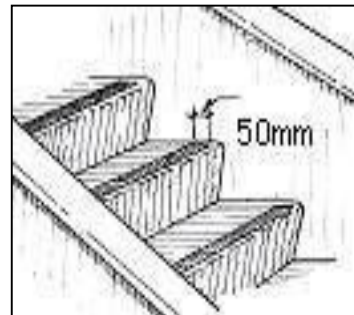
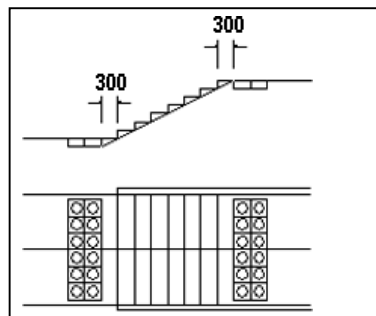

Figure 5.14 Step edges with bright contrasting colors



## HANDRAILS

- For a multistoried building, provide tactile features indicating the floor level on the handrail/ end of the rail to children with visual impairments (e.g., indicate the floor level on each handrail by use of raised dots, where one dot indicates first floor, two dots indicate second floor, and so on)
- Should be circular in section with a diameter of 38-45mm (**Photo 5.15 and Fig. 5.16**)
- Have at least 50mm clear knuckle space from the surface to which they are attached
- Provided at two levels - height of 760mm and 900mm from the floor level
- Extend by at least 300mm beyond the head and foot of the flight and ramp in the line of travel and grouted in the ground
- Ends to be either grouted in the ground or wall or rounded off
- Should be in bright color contrast to the surroundings (preferably red/yellow)

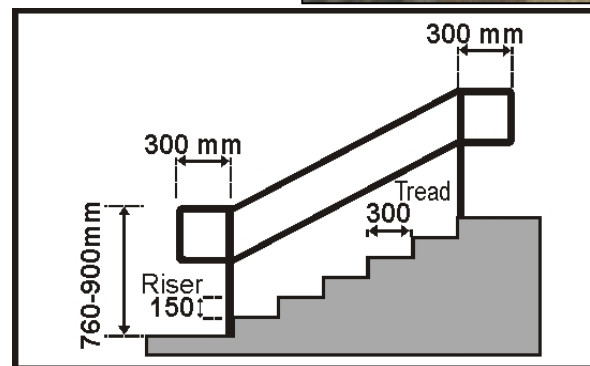
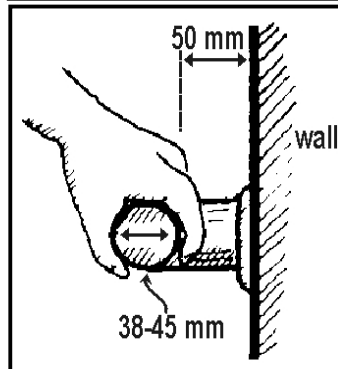

Photo 5.15 Handrails with circular ends

Figure 5.16 Standards of handrails along staircase

## Floor Finishes: TACTILE PAVERS: GUIDING STRIP & WARNING BLOCKS

- Line-type blocks (**Fig. 5.17**) indicate the correct path/route to follow
- Dot-type blocks (**Fig. 5.17**) provides warning signal, to screen off obstacles, drop-offs or other hazards, to discourage movement in an incorrect direction and to warn of a corner or junction. Should be placed 300mm at the beginning and end of the ramps, stairs and entrance to any door
- Places to install warning blocks (**Fig. 5.18**):
  - In front of an area where traffic is present.
  - In front of an entrance/exit.
  - To and from a staircase or multi-level crossing facility.
  - In open space to orient persons with vision impairment.

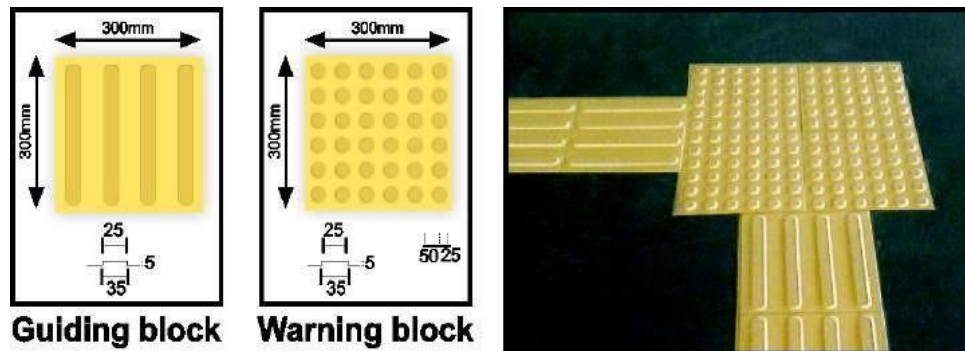

Figure 5.17 Tactile guiding and warning blocks

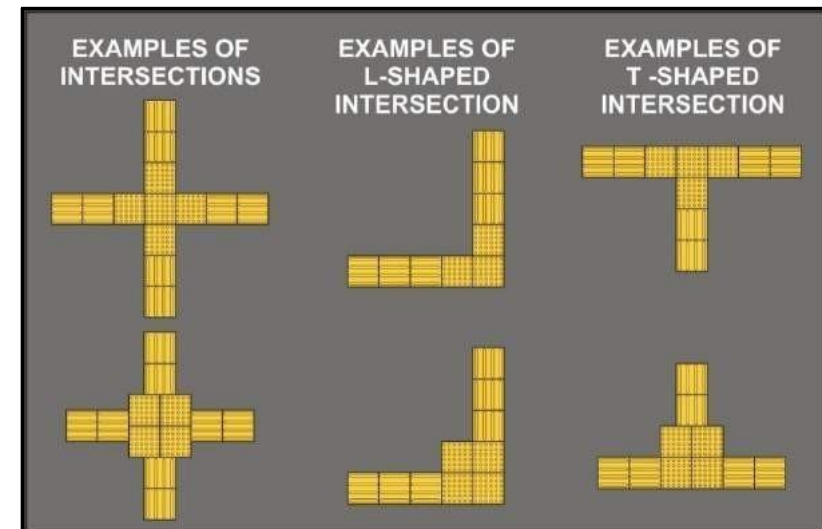
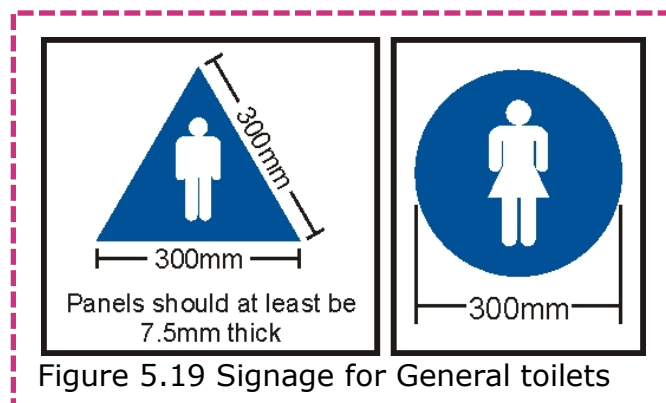

Figure 5.18 Examples of installation of tactile pavers

## GENERAL TOILETS

- All signage of general toilets should be in bold and contrasting colors
- For children with visual impairments, pictogram (male pictogram in triangle and female pictogram in circle) marked on plates along with Braille & raised alphabets to be mounted on wall next to door near the latch side, at a height between 1400mm-1600mm (**Fig. 5.19**).
- Warning strip/ thin rubber door mat to be provided 300mm before the toilet entrances
- Availability of sanitary material and disposal mechanism such as incinerators should be provided for the girls. Running water in the girl's toilets is essential for Menstruation, Hygiene and Management (MHM). Overhead water storage tanks should be provided to get piped water facility
- All toilet facilities should incorporate fire alarms with audio and visual systems
- Alarms must be located so that assistance can be summoned, both when on the toilet pan i.e., at 900mm height and lying on the floor i.e., at 300mm, from floor surface
- Toilet seat/WC or the background tiles shall be in contrast color for the benefit of children with low vision and to create visual contrast



**Toilets-** some children have difficulty with commodes and others with squatting toilets (Indian seat); at least one of each kind should be provided

- Water and soap for washing hands not only helps in learning safe hygiene management but also helps in attitude change of washing hands, especially in villages, where most people defecate in open and do not wash hands.
- For adolescent girls, running water is essential for their menstruation hygiene management.

- Accessible, usable and functional toilet facilities should be provided for all children. For children with disabilities, it is essential that toilets should have illumination, doors and roof for safety and privacy; otherwise, they are bound to remain out of school.

### ACCESSIBLE URINALS

- Accessible urinal should be provided in the beginning of the urinal row.
- One urinal should be modified – step less entry and chest support grab bar should be provided
- At least one of the urinals should have grab bars to support ambulant children with disabilities (for example, children using mobility aids like crutches)
- Urinals shall be stall-type or wall-hung, with an elongated rim at a maximum of 430mm above the finish floor.
- This is usable by children, short stature children and wheelchair users
- There should not be any step/ level difference in front of accessible urinal
- At least one of the urinals in all Boy's/Gent's toilets on all floors should have grab bar; installed on each side and in the front to support ambulant children with disabilities (for example, crutch users)
- The front bar is to provide chest support; the sidebars are for the user to hold on to while standing (**Photo 5.20**).

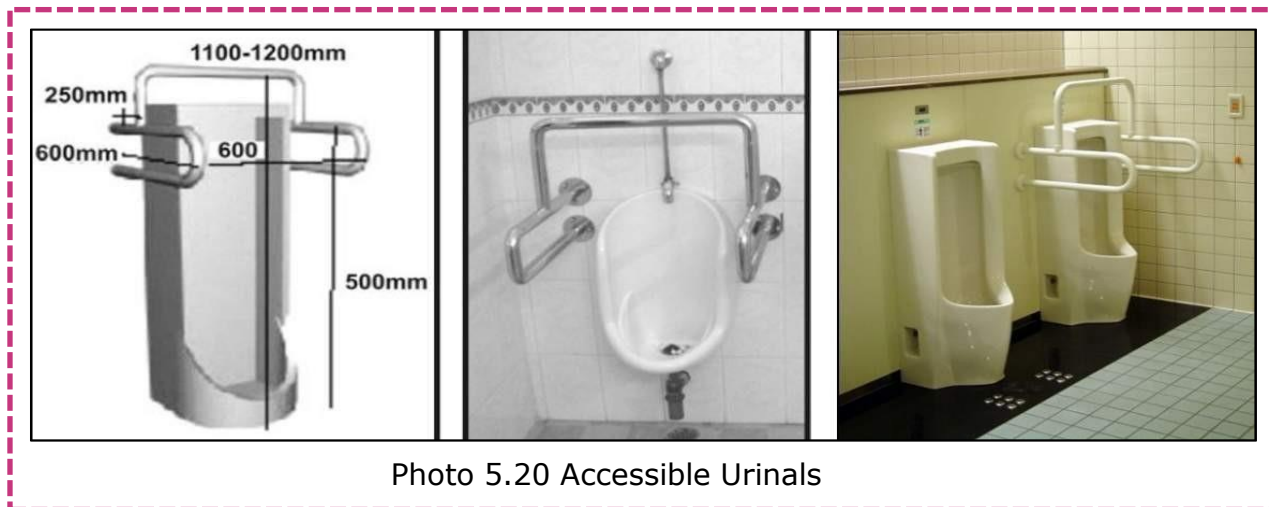

Photo 5.20 Accessible Urinals

## ACCESSIBLE TOILETS

- Accessible toilets (also termed as CwD's toilets) should be located next to or within 30m of the main entrance/ exit of the school building
- A minimum of one toilet compartment should have enough floor space for wheelchair users to enter and exit; clear floor space should be 2000mm x 2200mm minimum
- Provide a door of clear opening of at least 900mm with the door swing outwards or be folding or sliding type

### Toilet cubicle

- Should have slip resistant flooring
- A switch near the WC (one at 300mm and the other at 900mm from the floor level), which activates an emergency audio alarm at the attendant desk, staff room, etc. should be provided
- Flooring to be anti-slip/matt finish
- Anti-slip/ matt finish flooring
- Doors should have a horizontal pull-bar, at least 600mm long, on the inside of the door, located so that it is 130mm from the hinged side of the door and at a height of 900-1000mm
- Handrails all through the toilet cubicle walls should be provided for support and balance

### Water Closet (WC)

- Have clear space of not less than 900mm wide, next to the water closet to facilitate side transfer
- The top of the WC to be 450-480mm from the floor
- Grab bars for WC: on the transfer side swing up type and on the wall side L-shape grab bar
- Provide movable U-shape grab bar on the transfer side and L-shape grab bar on the adjacent wall **(Photo 5.21)**.
- Centerline of the WC to be located between 460-480mm from the adjacent wall

**Accessible Toilets**  
can be used by both male and female and helps caregivers with opposite sex to assist children with disabilities

- Seat of the WC to be 450-480mm from the floor **(Figure 5.22)**.
- If the WC is center placed i.e., the wall is more than 500mm away from the WC, movable grab bars on both sides to be provided
- Health faucet/ handheld spray should be provided at height between 500-800mm

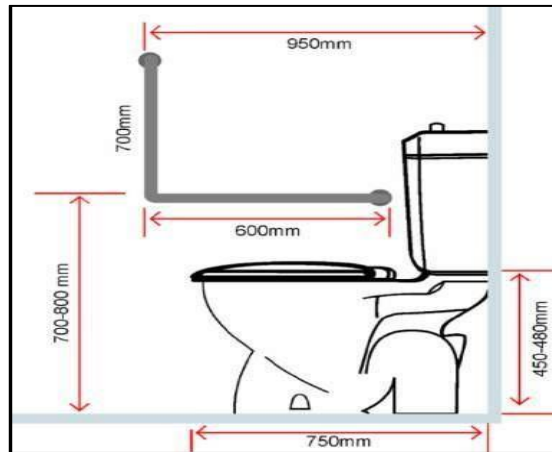

Photo 5.21 Grab bars for WC

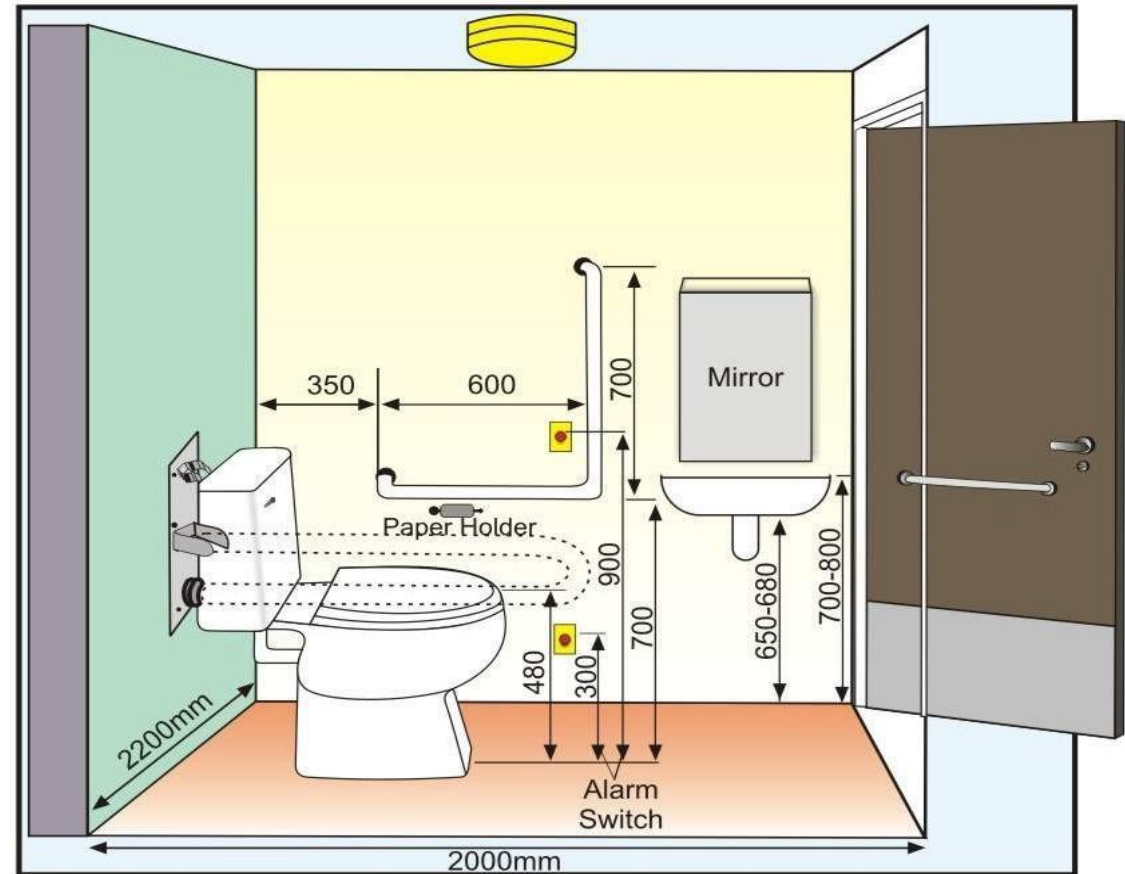
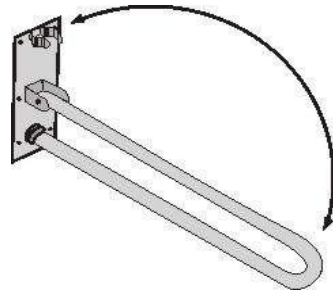
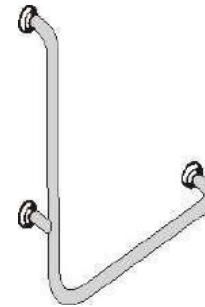

Figure 5.22 Standards for accessible toilet



**Figure 5.23 U shape (moveable)**



**Figure 5.24 L shape grab bar**



**Figure 5.25 signage for toilets/ bathrooms**

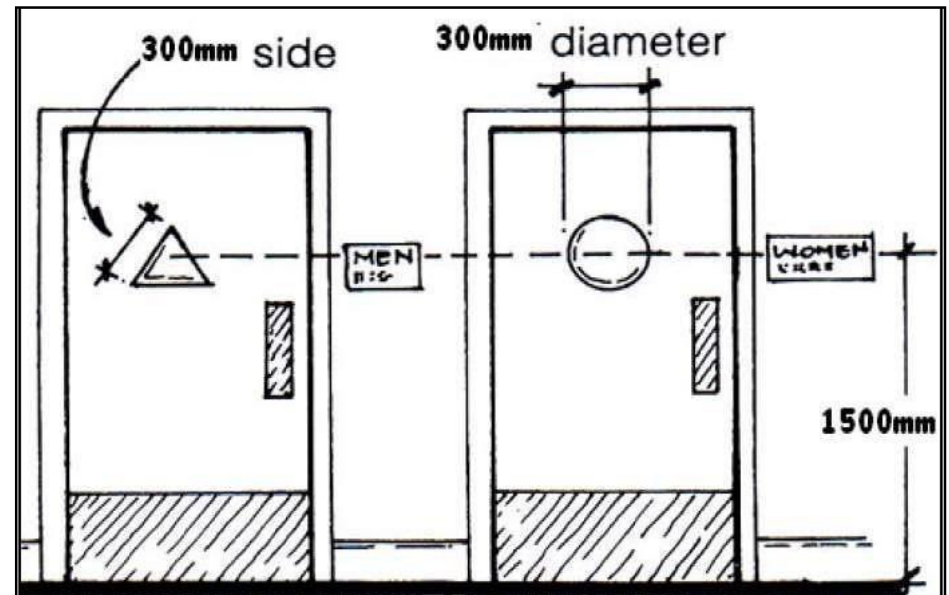

**Figure 5.26 Tactile signage placement on door of toilet**

## WASHBASIN

- Warning tactile paver should be placed before washbasin for children with visual impairment to identify location of wash basin **(Photo 5.27)**.
- They should be of dimensions 550mm and 410mm, so mounted that the top edge is between 700mm-800mm from the floor; and have knee clearance of at least 760mm wide by 200mm deep by 650mm-680mm high **(Figure 5.28)**.
- Lever type handles for taps are recommended **(Photo 5.29)**.
- Mirror's bottom edge to be 1m from the floor and the mirror may be inclined at 25° angle to get proper image of a children in seated height.
- U-shape moveable grab bars are proposed on both sides of the washbasin.



**Figure 5.27 Warning pavers**

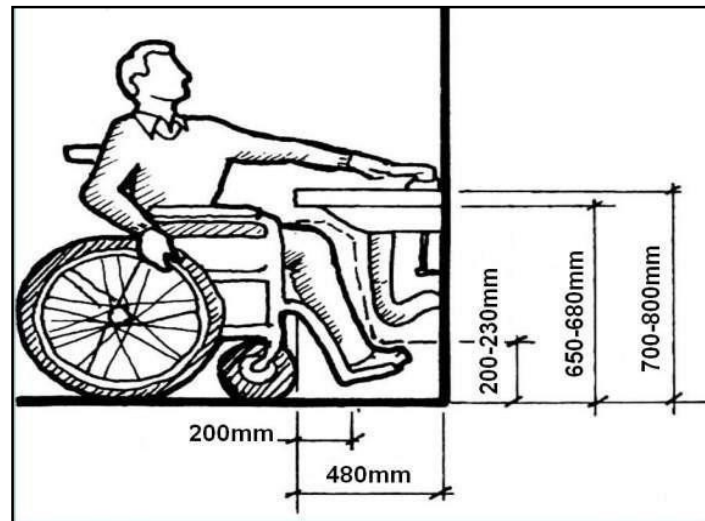
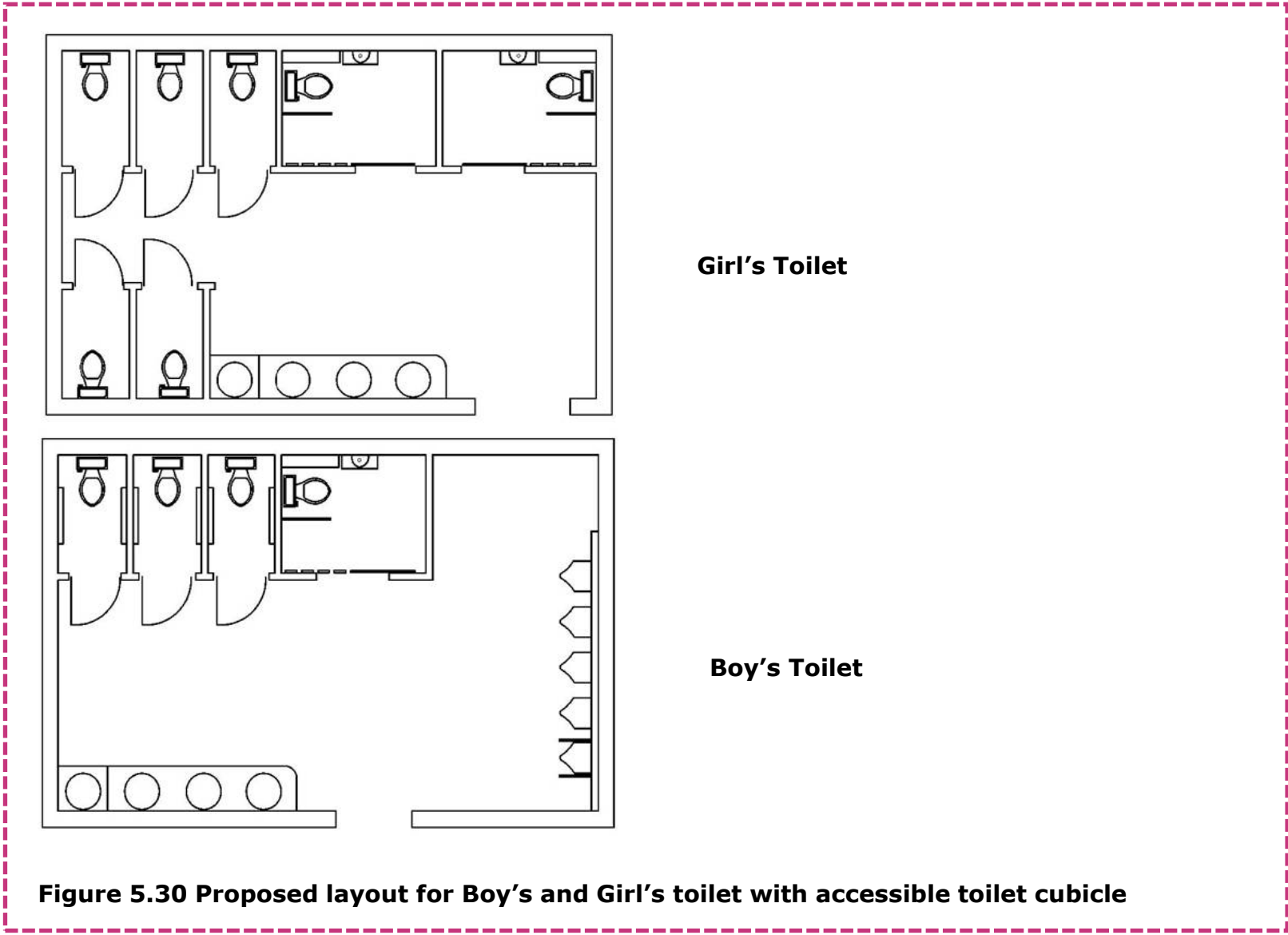

**Figure 5.28 Accessible washbasin**



**Figure 5.29 Lever type handles for taps for washbasin**





## INDIAN SQUATTING SEAT

- For children with locomotor disabilities who not using wheelchairs, Indian squatting seat should be provided with grab bars and clear floor space of 1200mm x 1500mm minimum. Door should have two-way open hinges;
- Signage for Ladies and Gent's toilet in Braille and pictogram should be provided (**Figure 5.31**);
- Clear floor space 1200mm x 1500mm;
- Vertical grab bar should be provided, which helps in assisting a child with reduced mobility to lower into squatting position and then rise into standing again;
- Horizontal grab bar should be provided which helps in balancing and stabilizing, when reaching for water/cleaning self (**Figure 5.32**);
- Health faucet/ handheld spray should be provided at height between 300-400mm;
- Door handle, lock and storage for crawlers, children and standing users at two levels/heights 300mm and 800mm; and
- Clothes hanging hook for seated and standing users at 800mm and 1000mm.

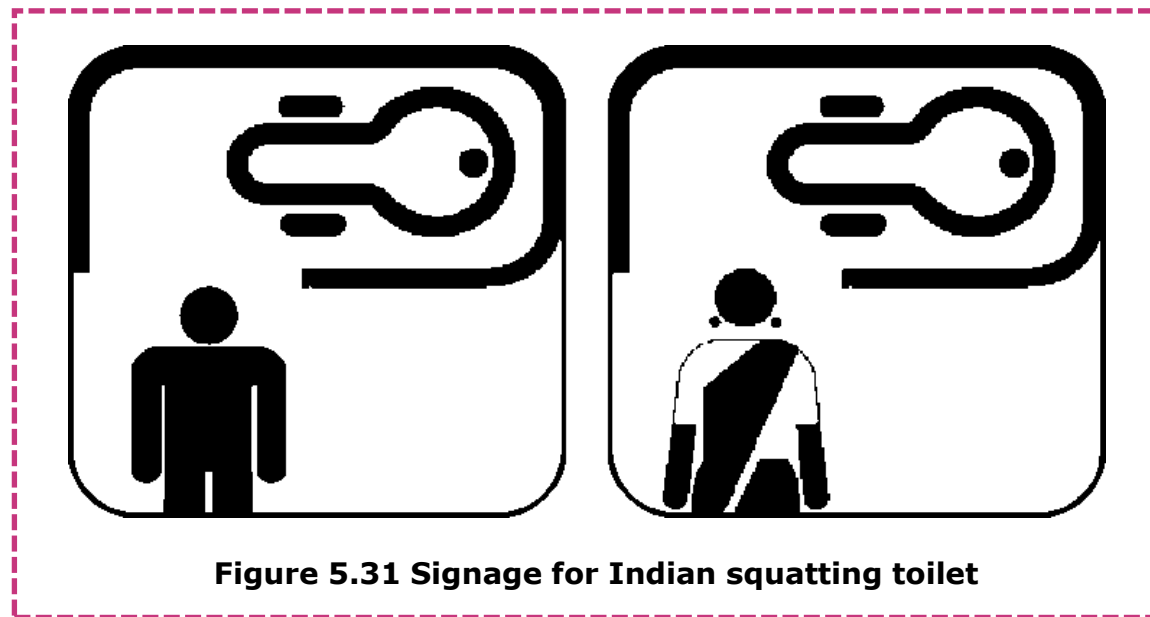

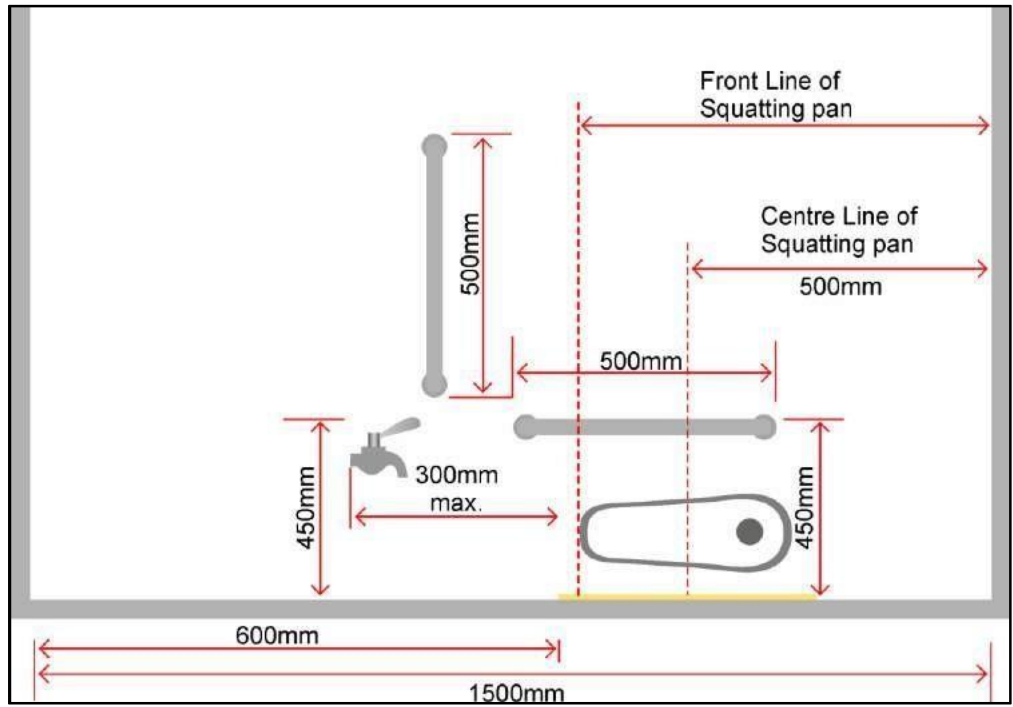

**Figure 5.32 Side view of Indian/Squatting Toilet Plan**

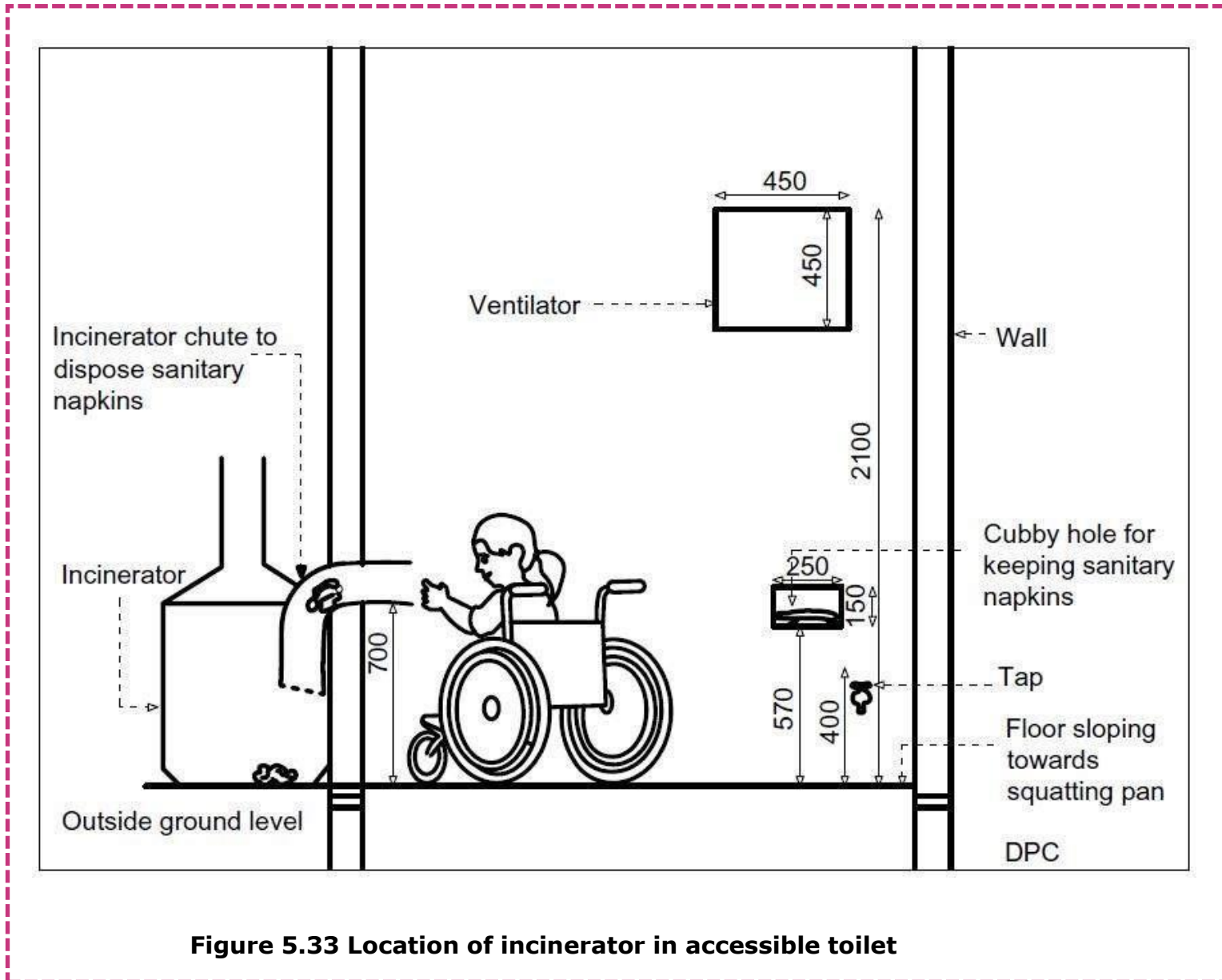

**Figure 5.33 Location of incinerator in accessible toilet**

**Do's**

- Straight and unobstructed paths to toilets which helps children with visual impairments and those using mobility aids;
- Functional toilets with regular maintenance of water - inlet, availability, storage and drainage;
- Pictogram- male & female symbol with raised outline and bright colour contrast for children with visual impairments;
- Running water for Menstruation Hygiene Management and dustbin in girls' toilets for disposal of sanitary pads;
- Use of indigenous material like bamboo, wood, mud for access provision;
- Wide door- 3ft minimum, ventilation and illumination and paved/ firm surface;
- Accessible toilets should be provided next to existing/ general toilet cubicles;
- Accessible toilet cubicle with western commode seat can be provided by combining two cubicles and creating space of 2000mm x 2200mm in refurbishment of old toilets;
- Grab bars (U and L shape) are required next to WC for independent transfers by most children.

**Don'ts**

- Location of toilet- should not be under the tree, as during storm/heavy rains trees fall and block entrance in the toilets;
- Toilet block
- Barriers/ obstruction- in the approach to the toilets;
- Less illumination or no illumination deters user to use it in adverse weather conditions and night;
- No facility for hand wash;
- No piped water.

## ROOM AND WINDOWS

- Room windows should open inside the room and not in the corridor/circulation area
- Height of the window should be 600-1450mm, enabling the resident to see out of it, when seated or in bed (**Figure 5.34**)
- Remove glare from shining objects and window by providing blinds/curtains
- Window glasses to be provided with wire mesh/grill with mosquito net to prevent insects and for safety of children with disabilities
- Operable devices such as handles, pulls, latches and locks should be:
  - Provided between 900-1000mm
  - Lever handles and push type
  - Operable by one hand does not require fine finger control, tight grasping, pinching or twisting to operate
- **Room:** Light/fan/AC switches to be provided at a height between 800-1000mm
- **Alarms:** Audio and visual (flashing bulb) alarm facility should be provided in every room

**Furniture in the classroom/  
hostel room should not be  
reshuffled frequently;  
however, if necessary,  
children with visual  
impairment should be well  
oriented**

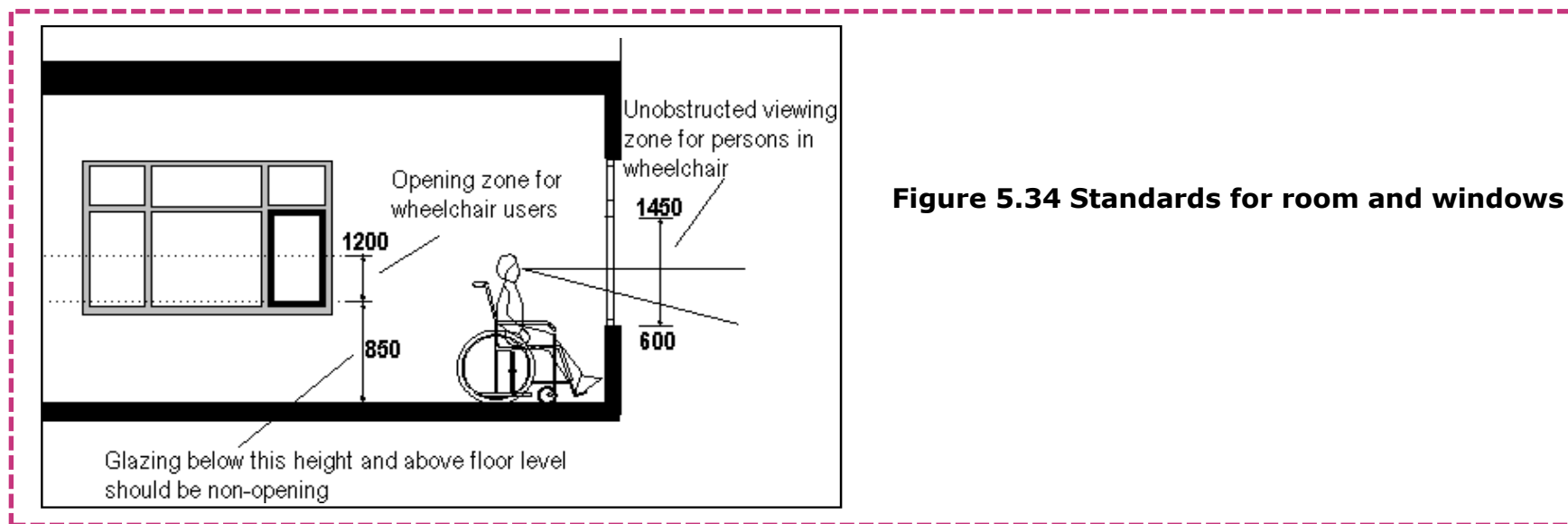

**Figure 5.34 Standards for room and windows**

## DOORS

- All doors- classrooms, seminar hall, canteen, toilets, pantry and practical labs, etc. should provide a clear opening of 900mm minimum
- Be fitted with a lever action locks and D-handles of circular section, between 850mm and 1100mm from floor level
- Be color contrasted with the surrounding wall and should not be heavier than 20N to open
- Kick plates are recommended 300mm from the bottom, to resist wear and tear (**Figure 5.35**)
- Wherever required, doors should be fitted with vision panels at least between 900mm and 1500mm from floor level

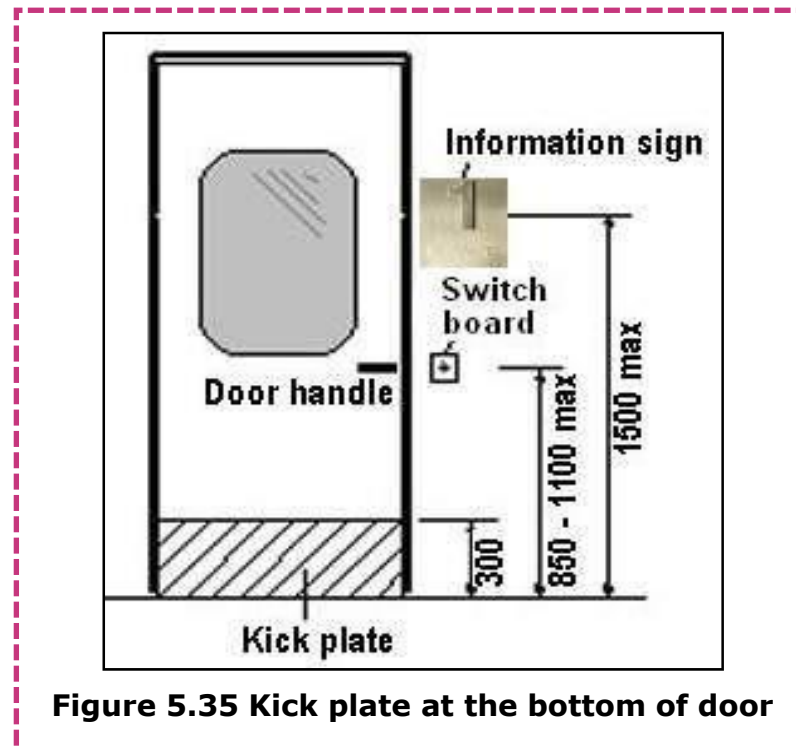

**Figure 5.35 Kick plate at the bottom of door**

## DOOR ACCESSORIES AND HARDWARE

- **Threshold/ channel** should either be embedded in the ground or beveled as per the illustration (**Figure 5.36**)
- **Operable devices:** such as handles, latches and locks should be:
  - Provided between 800-1000mm
  - Lever handles and push type
  - Operable by one hand and do not require fine finger control, tight grasping, pinching or twisting to operate (**Figure 5.37**)
- **Glazed/glass doors and fixed glazed areas:** should be made visible by use of a clear, color and tone contrasted warning or decorative feature that is effective from both inside and outside. These should be visible under any lighting conditions, e.g. a logo, of minimum dimensions 150mm by 150mm, set at eye level, can be provided
- **Foot mats:** either recessed in the ground or thin rubber mats to be provided, for children with visual impairment to easily detect all entrances
- **Kick plates:** (aluminum/rubber) at 300-400mm of height from the floor level to be provided on the doors (to avoid wear and tear) (**Figure 5.37**)

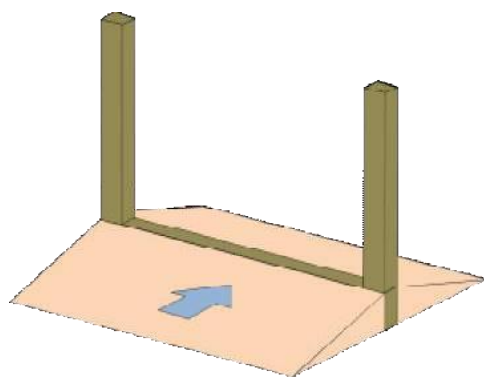

**Figure 5.36** Bevel edge on the channel/projection



**Figure 5.37** Standards for kick plates, information signage & door hardware

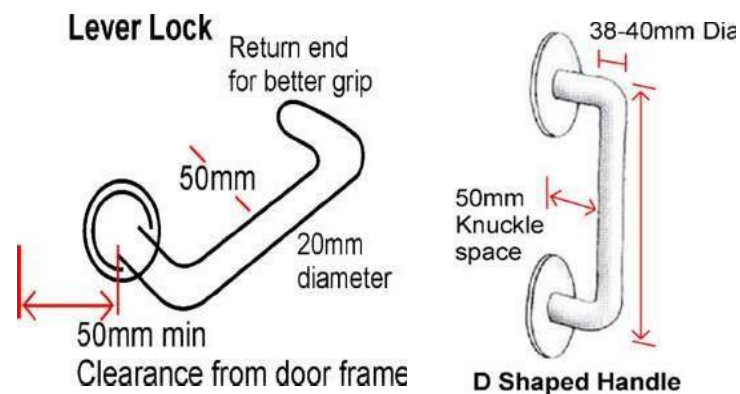



## DRINKING WATER

- Signage should be provided for drinking water area
- Taps to be at two heights- 400mm and 800mm and lever type handles for taps are recommended
- A lowered washbasin for children using mobility aids such as wheelchair, crutches, walker etc. should be provided
- Washbasin be of dimensions 520mm and 410mm, so mounted that the top edge is between 700mm-800mm from the floor; have a knee space of at least 760mm wide by 200mm deep by 650mm-680mm high (**Figure 5.38**)
- This allows both front and parallel access to taps for students using mobility aids like wheelchair, crutches etc.
- Multi-tap and multi-level drinking water unit with cubby hole for soap is a child friendly design and should be provided (**Figure 5.39**). There are two options and anyone of these can be provided.

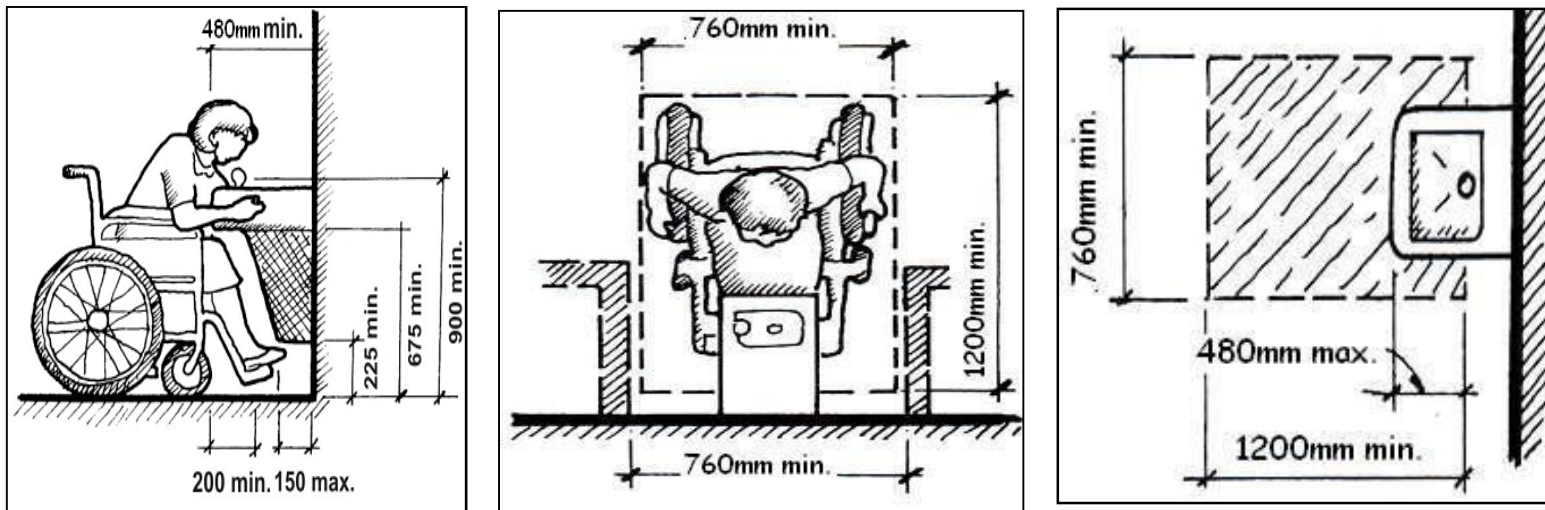

**Figure 5.38 Standards for accessible drinking water units**

## Option I

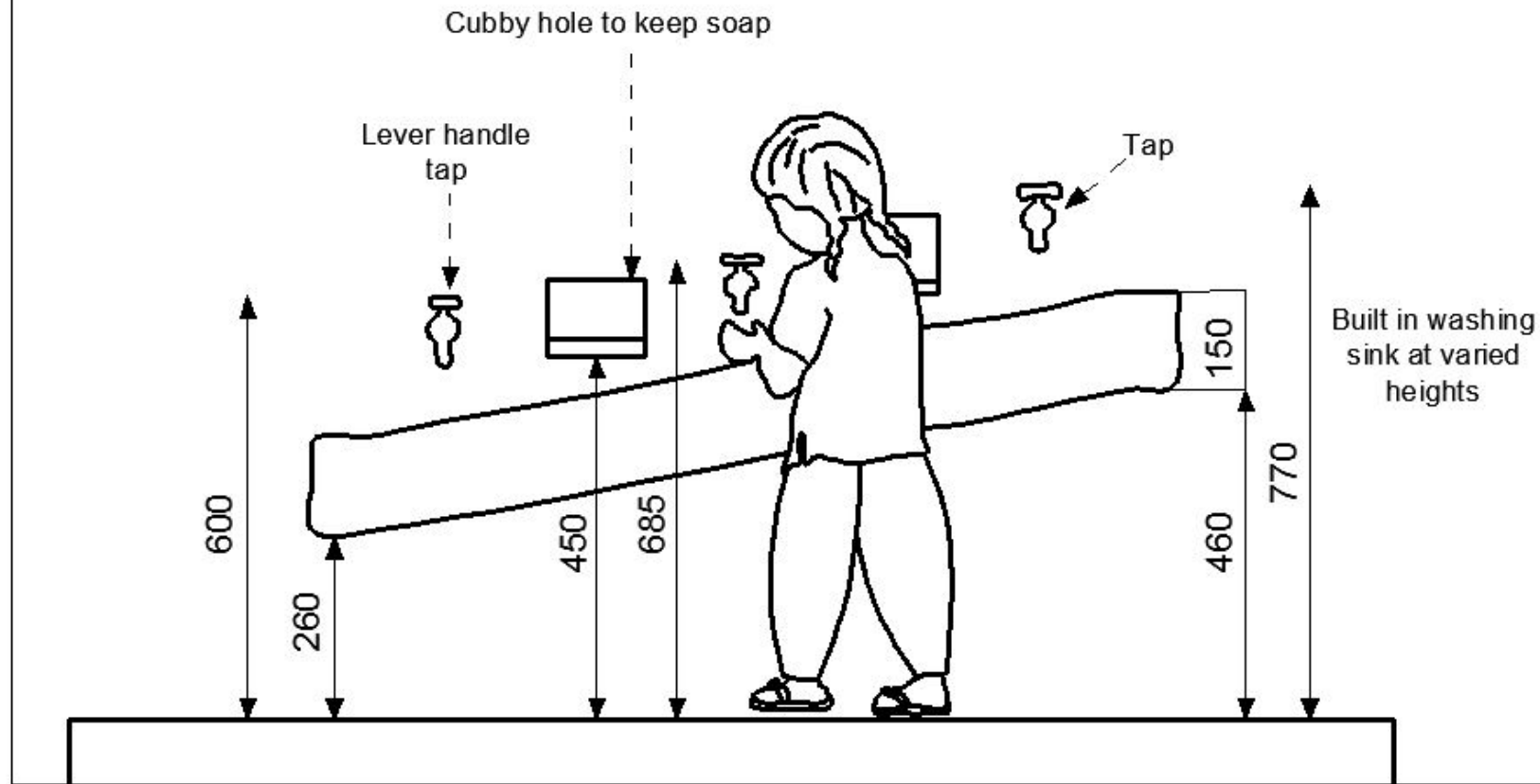
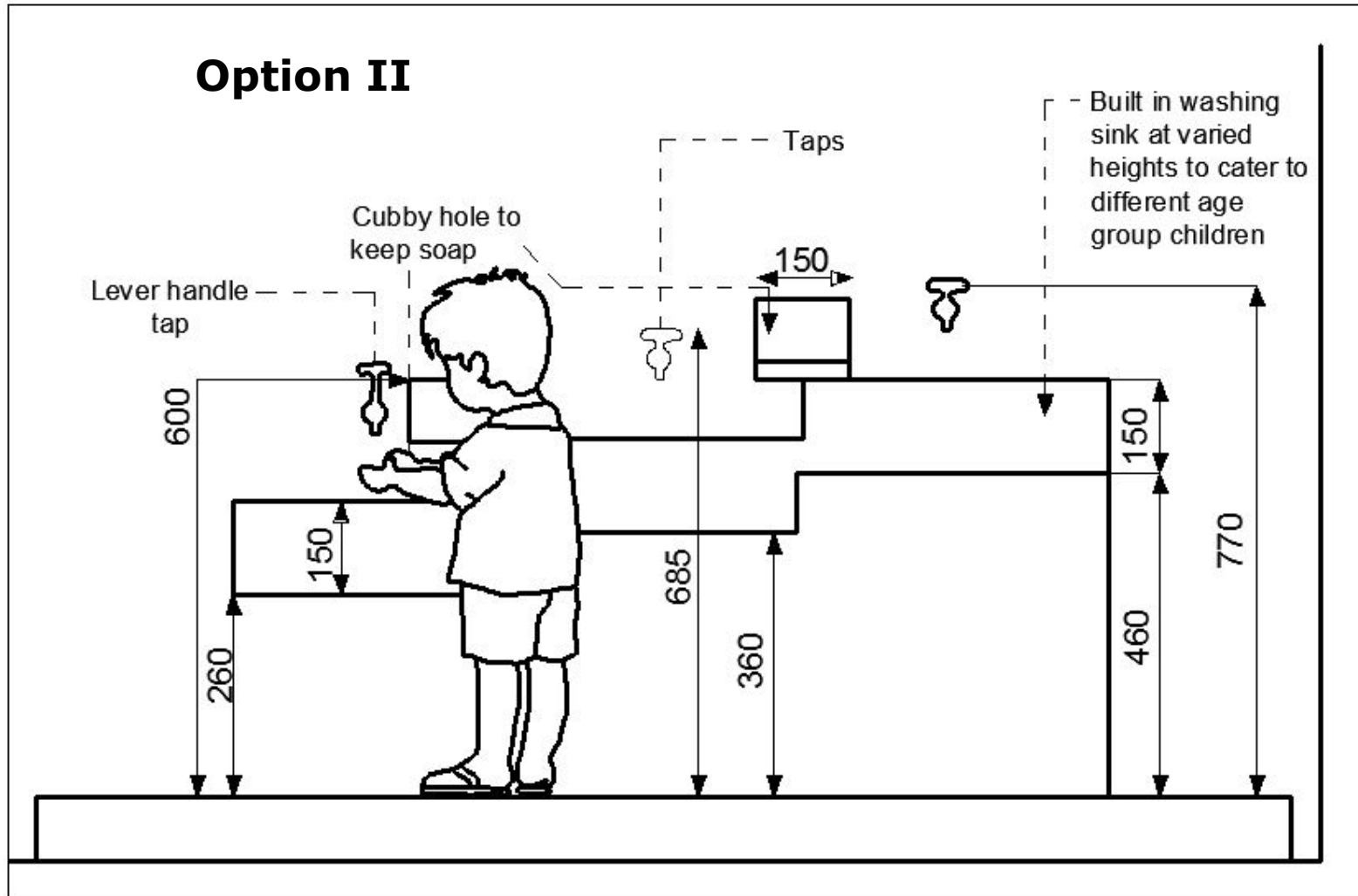

Figure 5.39 Option I- Standards for accessible drinking water units



**Figure 5.39 Option II- Standards for accessible drinking water units**

## CLASSROOMS, LIBRARY, LABORATORY, RESOURCE ROOM AND ACTIVITY AREAS

- There should be specified norms for teacher child ratio per classroom. Education, growth and evacuation are facilitated by providing adequate space per child.
- In the rooms/laboratory/activity area, storage space of various kinds (shelves, cupboards and drawers) should be 340mm-1200mm from the floor level, allowing front approach and 230-1300mm for side approach (**Figure 5.40**)
- Almirahs and drawer handles should be lever lock with D-shape handle, which may be easily grasped by a child with limited gripping or pulling strength (not more than 20N)
- Sufficient floor space- 900mm-1200mm should be provided for wheelchair users to maneuver around green boards in classrooms, in between library stacking shelves and while opening doors of cupboards/almirahs in hostel rooms.
- Comfortable forward reach is between 380-1200mm and maximum height of shelves over worktop should not be more than 1000mm.
- **Libraries**
  - All open book stacks should be accessible.
  - All library facilities and equipment should be accessible.
  - A special room should be provided for people with hearing and vision impairment who need assistance while reading.
  - A silent room/ space is preferred for children with Autism.

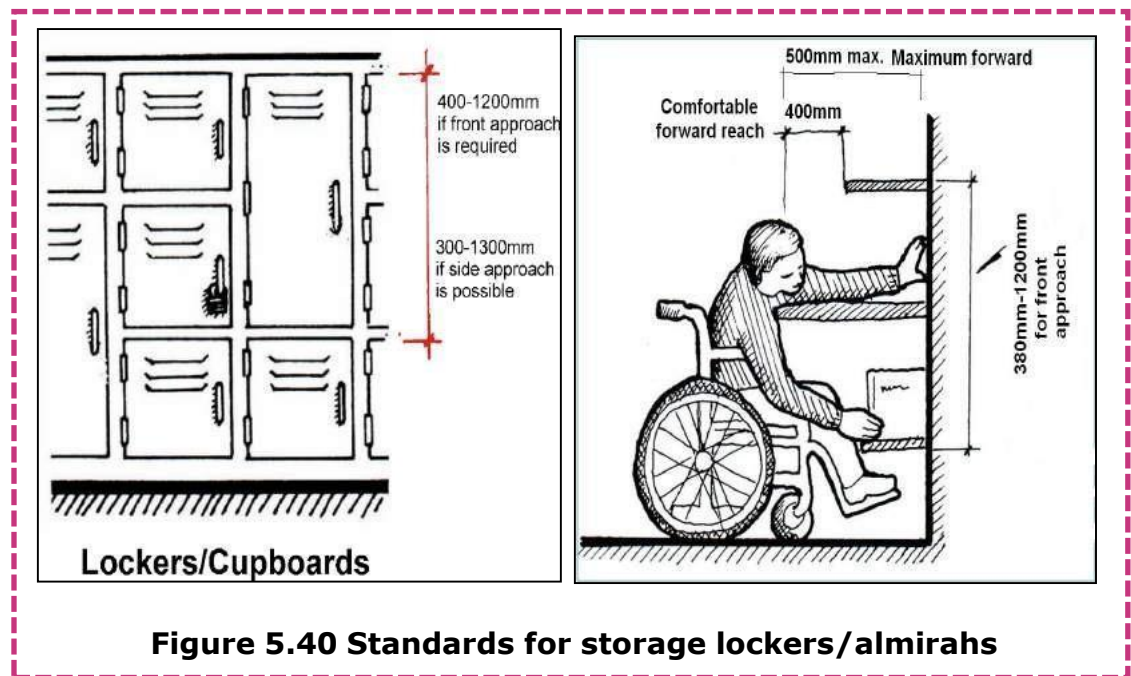

**Figure 5.40 Standards for storage lockers/almirahs**

## FURNITURE AND MULTI USE TABLES

- In the classrooms, some benches should have detached (separated) table and seats to facilitate ease of movement of assistive devices users such as walkers/ crutches, etc.
- A knee clearance of at least 650mm is required.
- The desks should be used by maximum 2-3 children.
- Desk should be modified by providing a shelf or storage space under it so that children can keep their bags in it and use the seat space for resting purpose.
- Height of the seat and desk should be provided / adjusted as per the child size and height.
- Glazed, mirror polish flooring can cause slip hazards. Anti-skid flooring is recommended in the entire school.
- Glazed tiles also produce glare from natural light and cause discomfort to students with low vision.
- Activity/study/dining tables should not be more than 800mm high from the floor, with a minimum knee clearance of 650-680mm high and 280-300mm deep (**Figure 5.41**).
- Space around the table should be around 1200mm x 800mm.
- Matt finish light color table surface are recommended instead of glazed surfaces that produce glare



**Photo 5.41 Easy to use school furniture**

Source: <http://www.panfurniture.com/schoolfurniture.asp>

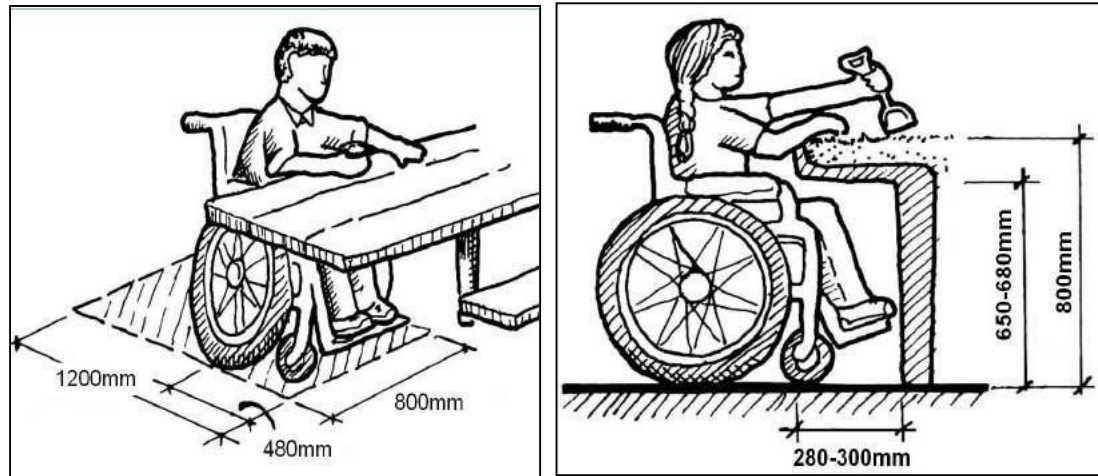

**Figure 5.42 Standards for multi-use tables**

**Keeping the body straight from side to side**

Even with a firm board seat, this boy's body sags to one side. This can lead to increasing curve of the spine (scoliosis).

Hip guides may help him sit straighter

Sometimes, hip guides alone are not enough.

**Figure 5.43 Chair (Seating) Adaptations for Children with Cerebral Palsy**

## AUDITORIUM, MID DAY MEAL AREA/ CANTEEN, GYMNASIUMS AND POOLS

- All common areas, including entry and exists, seating arrangements, equipment's in the gymnasium and swimming pool should be made accessible.
- Use of multi-use tables with adequate leg and knee space is easy to use furniture in these areas **(refer section 5.2.18 and figure 5.44)**
- Washbasins / sinks in canteen/mid-day meals area, provide one accessible wash basin **(refer section 5.2.11)**
- Auditoriums should have induction loop system for children with hearing impairments.
- Auditoriums and open areas where events are conducted, spaces for wheelchair users should be clearly marked with international symbol of accessibility and should have dimensions complying with figure
- Some seats with removable or flip-up armrests should be provided at row ends to accommodate a wheelchair user or a person with limited ambulatory mobility. A level floor area for wheelchair users should be placed at row ends and should be scattered on different levels so as to have a variety of seating and viewing locations **(Figure 5.42)**.
- The number of spaces designated for wheelchair users in a seating area can be estimated according to Table 5.1:

**Table 5-1: Seating for wheelchair users in Halls/auditoriums**

Number of seats in a seating area	Number of required spaces for wheelchair users
up to 600	6 i.e., 1/100
up to 1000	6 + 2
over 1000	8+1 for each additional increment of 1000 seats

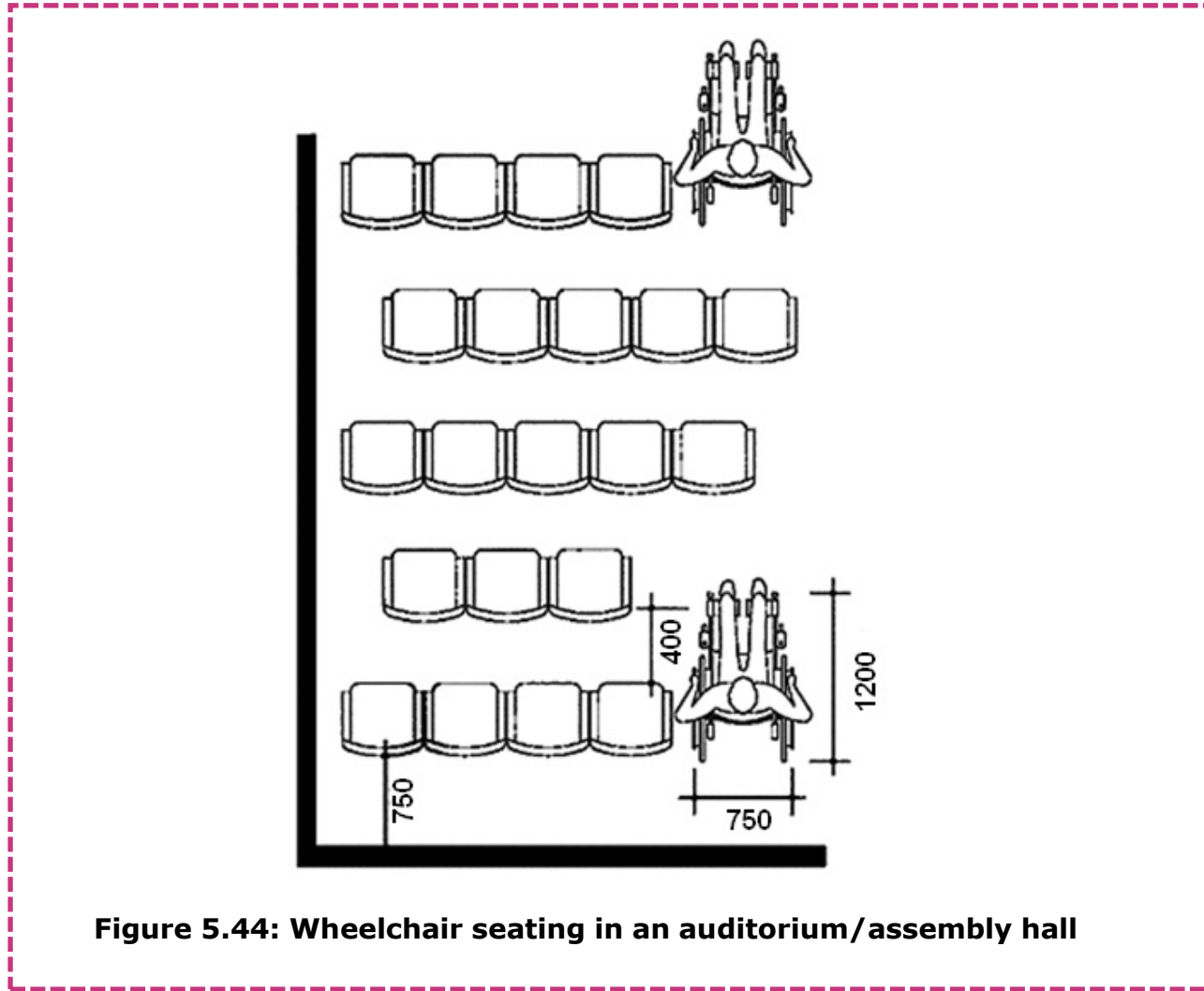



## LABORATORIES

- Use of multi use tables with adequate leg and knee space is easy to use
- furniture in labs (**Refer section 5.2.18 and figure 5.45**)
- For labs having washbasins / sinks, provide one accessible wash basin (**Refer section 5.2.11**)
- Writing surfaces or service counters should not be more than 800 mm from the floor and have clear knee space of 680mm (**Figure 5.45**)

**Figure 5.45: Counter tops/table height**

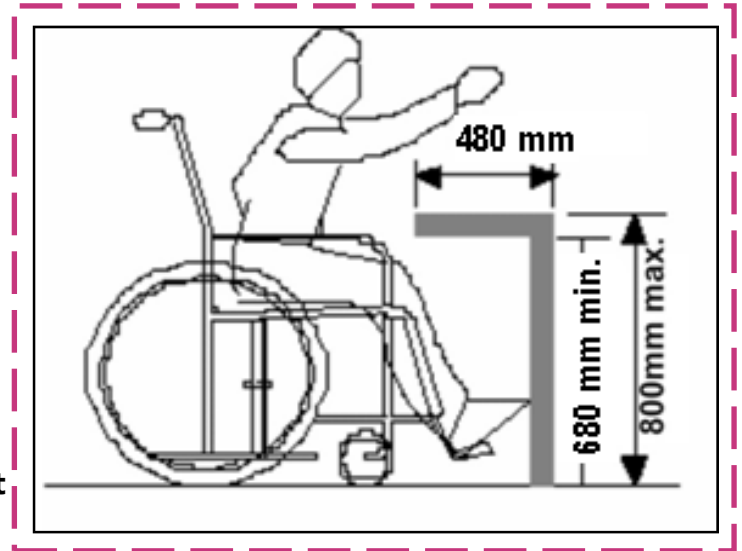

## SPORTS BUILDINGS

- Sports halls should be fully accessible.
- At least one shower room (**Section 6.3**), one washroom (**Section 5.2.10**), and one changing room per facility should be accessible to a wheelchair user.
- Spectators' seating areas should be provided for wheelchair users as specified (**Figure 5.44 and Table 5-1**)
- The clear width of the accessible entrance door should not be less than 900mm (**Figure 5.46**), preferable 1m and the width of the corridors or passageways leading to and from such access door should not be less than 1800mm.

**Figure 5.46: Door opening**

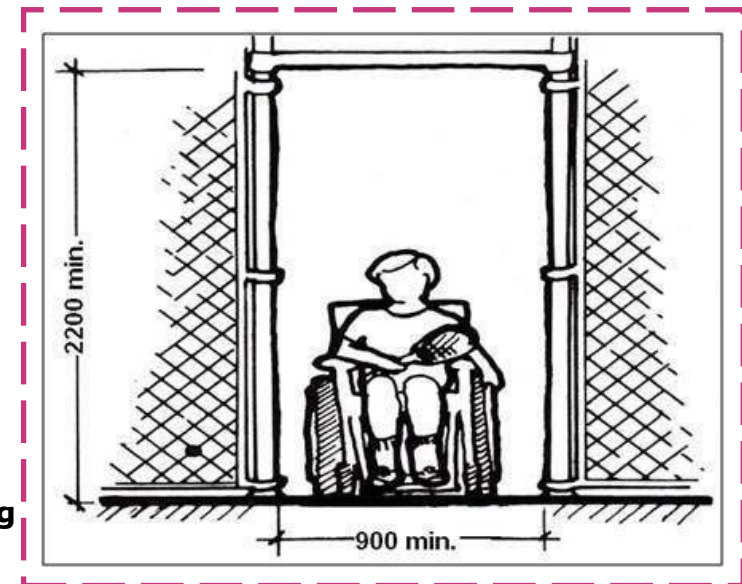

## LIFT

Wherever possible ramps are preferred than lift in the schools; if there is a space constraint, then lift shall be provided for multi-story schools.

- **Color:** lift door and panel should be in bright color contrast, instead of glazed steel or any other metallic shade that produces glare
- **Car space:** Internal floor space 1500mm x 1500mm minimum
- **Doors:** 900mm wide and closing mechanism to be adjusted to give adequate entry time. Alternatively, sensors should be installed
- **Call button:** at a reach of 800mm-1000mm; at least 450mm from any corner or wall to reach the call button
- **Control panel:** inside the lift preferably on both the sides, having buttons with Braille and also raised letters and in bright contrast from the background (**Figure 5.47**)
- **Audio announcement:** for door opening/closing and floor levels
- **Key plan:** of all floors to be placed inside the lift
- **Vision panels:** should be provided on the lift door at two levels-800mm & 1500mm
- **Level difference:** gap in level between the lift door and the floor surface should not be more than 10mm
- **Floor directory:** of the main facilities and services available on the lift landing, along with an accessible emergency egress route that clearly indicates the location of nearest refuge areas for children with disabilities
- The use of visually and acoustically reflective wall surfaces should be minimized within the lift car as visual reflections can cause discomfort and affect the visual acuity of children with visual impairments
- The floor of the lift car should be slip resistant and have similar frictional qualities to the floor of the lift landing to decrease the risk of stumbling
- The provision of a mirror on the wall of the lift car opposite the lift door is a positive aid to navigation for wheelchair users.
- It allows the wheelchair user to see if anyone is behind them and also to see the floor indicator panel
- The mirror should not extend below 900mm from the lift floor to avoid confusing children with visual impairments
- Be color contrasted with the surrounding wall and should not be heavier than 20N to open

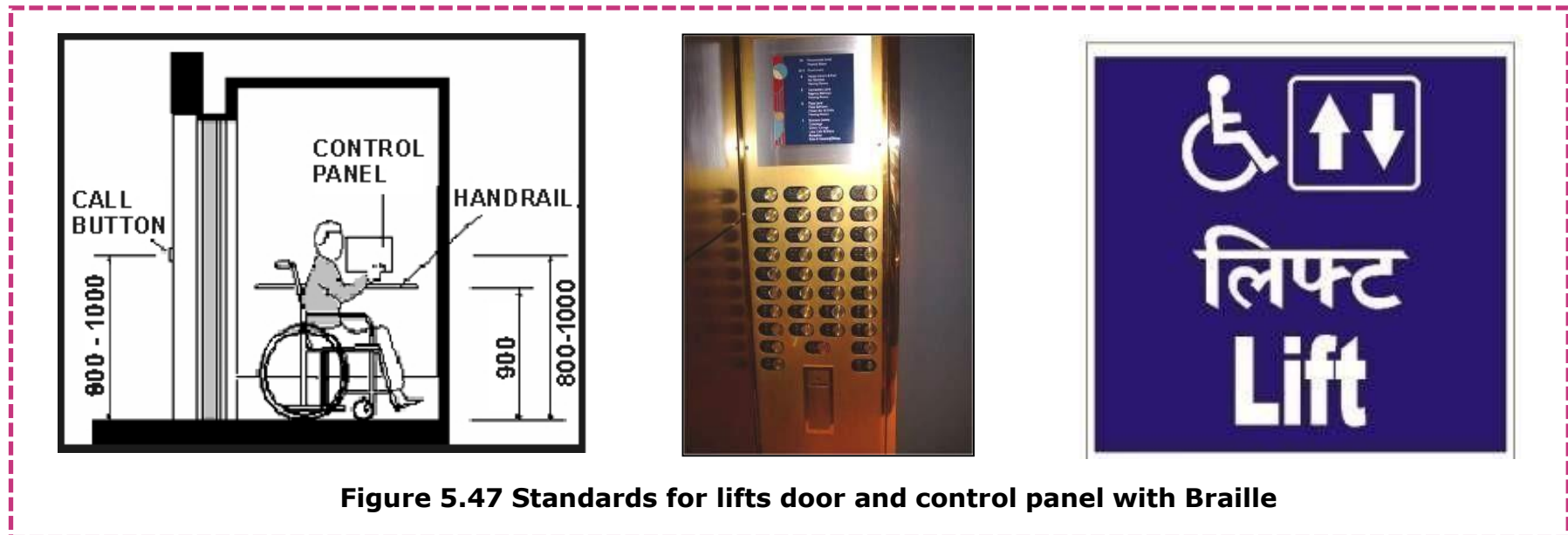

**Figure 5.47 Standards for lifts door and control panel with Braille**

### ILLUMINATION

- Adequate and well distributed lighting should be provided in all classrooms. Preferred illumination level between 350-500 lux.
- Glare from excessively bright lights should be avoided.
- Illumination should be provided on black board for lip reading by children with hearing impairment.
- Toilets, staircases and corridors should have illumination level between 100-150 lux.

### PLAYGROUND

- Paved pathway of 1800mm width minimum should be provided.
- In case of level difference, ramp to connect the pathway should be provided.
- Nearest sitting area to the paved pathway, under shed / tree to have clear space of 800mm x 1200mm for wheelchair users

# CHAPTER 6: HOSTEL



## 6.1. ENTRY & EXIT

- All entries and exits of the hostel should comply with section 5.2.1

## 6.2. ACCESSIBLE ROOM

- The room should be planned to provide a 1500 mm turning in space for wheelchair users, at least near all the doors.
- There should be a clear floor space of at least 900 mm × 1200 mm in front of all furniture.
- Bed for a wheelchair user should:
  - Have a height of 450-480 mm from the floor surface;
  - Be stable. Stability may be improved by placing the bed against a wall or in corner of the room (except for when the wheelchair user plans to make the bed); and
  - Be positioned to provide at least a 1500 mm turning in space at the transfer side.
- A bedside table or cabinet between 450 mm and 900 mm from the floor may be useful to hold a lamp telephone, necessary medications and a call bell if assistance is needed.
- Wall hook installed at a height of 1100 mm to 1300 mm may be a useful addition to the closet area.
- The closet should:
  - Have a clear floor space of at least 900 mm × 1200 mm;
  - Have the clothes bar at a height of 1200 mm from the floor;
  - Have shelves installed at various levels between 300 mm and 1150 mm from the floor surface;
  - Have door handle conforming to **(Section 5.2.14)**

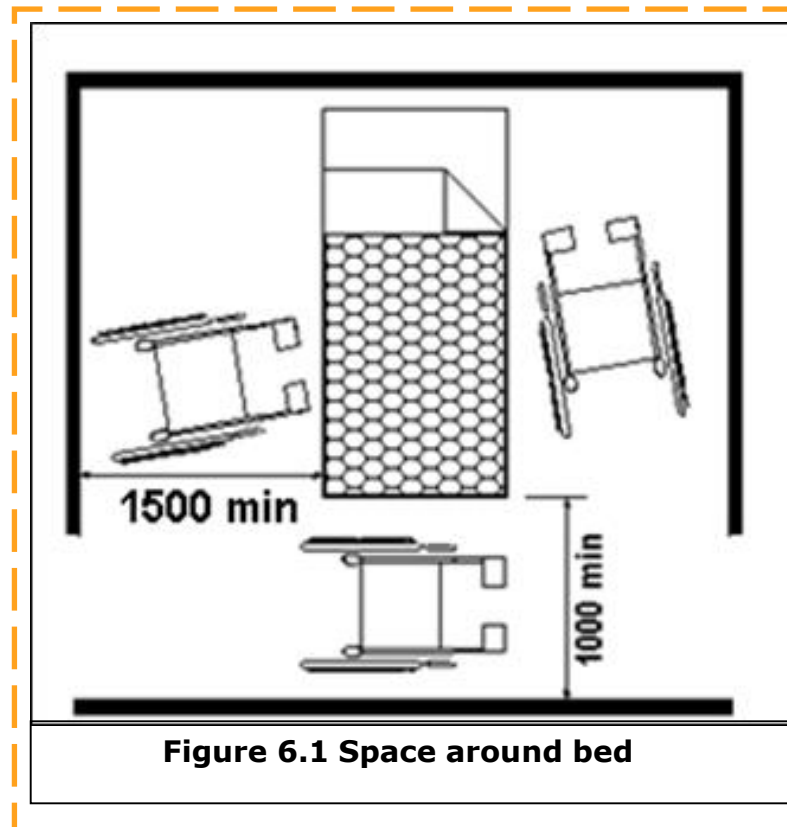

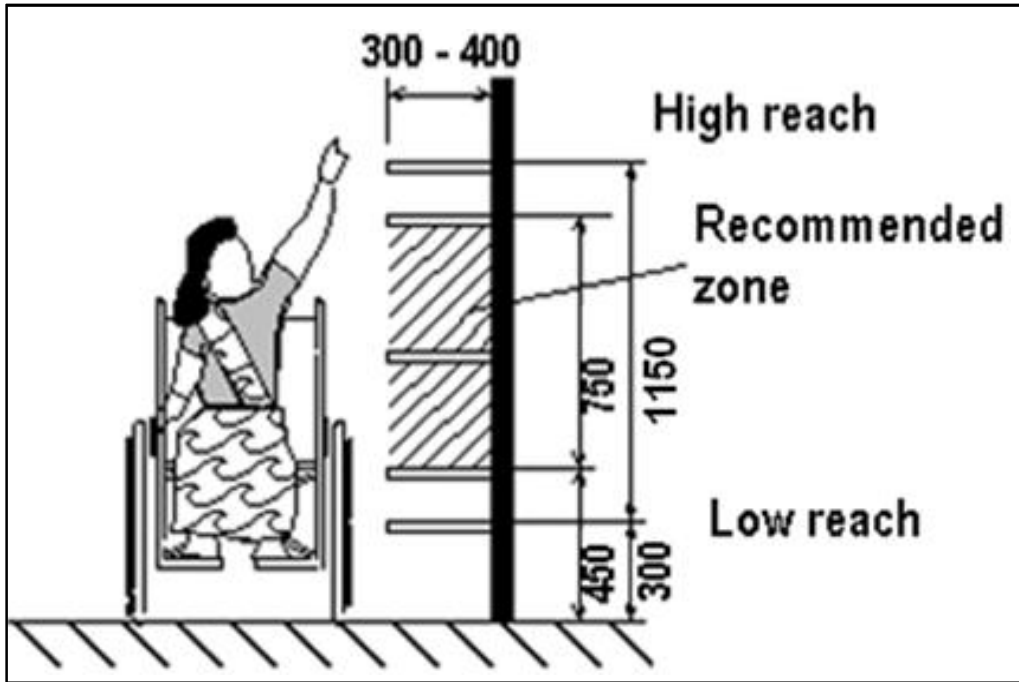

Figure 6.2: Storage space

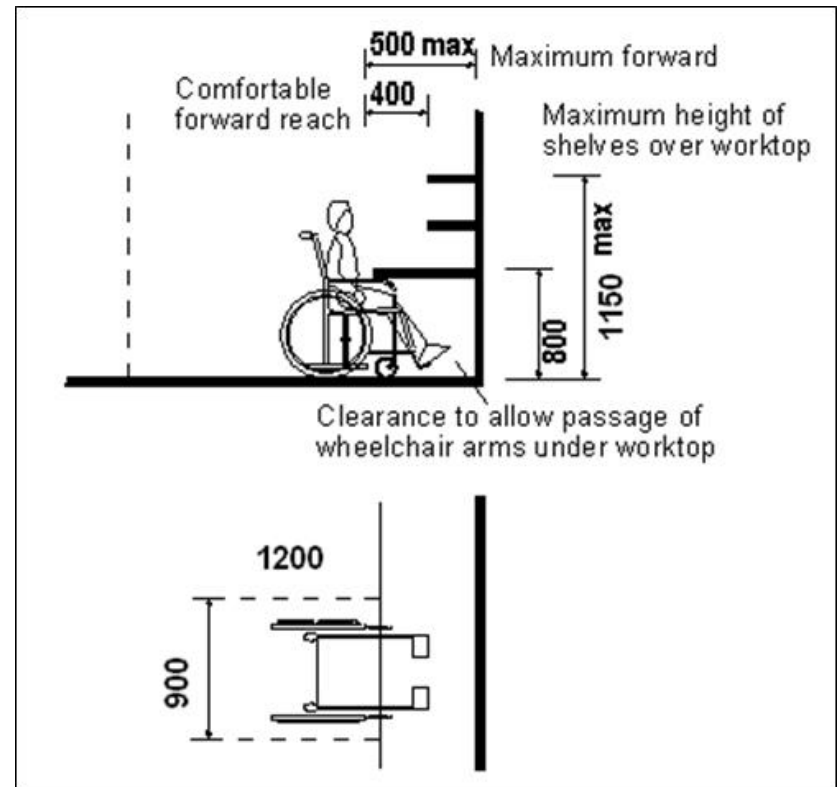

Figure 6.13: Shelves and cupboards

### 6.3. CANTEEN/ DINING HALL

- New canteens / dining halls and eating spaces should be accessible and persons with disabilities and elderly should use facilities and services.
- Old buildings should be retrofitted as per the standards given in chapter 4.
- In self-service canteens, tray slides and counters should be mounted at 800mm from the floor for wheelchair users. Food shelves should be mounted at a maximum height of 1200 mm and aisle space of minimum 900mm should be provided (**Figure 6.4**).
- Cantilevered tables or tables with straight legs at each corner are preferable to central pedestals that might restrict wheelchair access.
- Stools and high tables are not suitable for wheelchair users. Low tables should be provided as well.

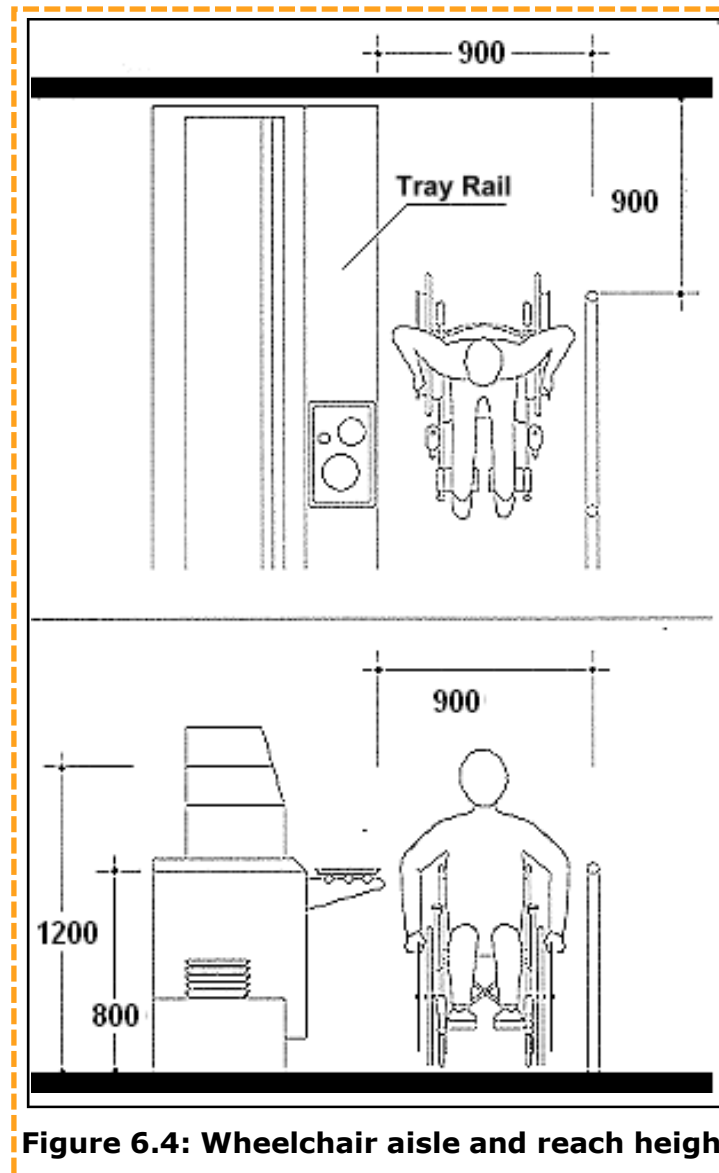

Figure 6.4: Wheelchair aisle and reach height

#### 6.4. ACCESSIBLE BATHROOM

- For individual accessible cubicles in Ladies and Gents toilets, signage should be provided as per Figure 6.5 and 6.6.
- For the benefit of the persons with vision impairment, all general toilets should have male pictogram in triangle or female pictogram in circle, marked on plates with raised alphabets and Braille (**Section 5.2.8**) put on wall next to door latch.
- Additional signage can be provided on the door as well (**Figure 6.5 & 6.6**).



**Figure 6.5: Unisex accessible (CWDS) toilet**



**Figure 6.6: Signage for Gents and Ladies accessible toilet cubicle**



## 6.5. BATHROOMS-SHOWER CUBICLES

### Size

- Shower cubicles should have minimum interior dimensions of 2000 mm x 2200 mm.
- A toilet cum shower room will have minimum interior dimensions of 2400mm x 2500mm
- The minimum clear floor space in front of the shower entrance should be 1350mm x 900mm with the 1350mm dimension parallel to the shower entrance.
- The floor of the shower should be slip-resistant.

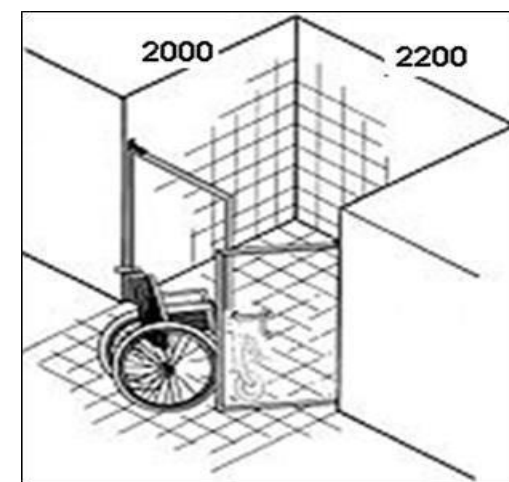

**Figure 6.7: Shower Cubicle**

### Grab bars for the shower cubicle should:

- Comply with Section 5.2.10;
- Have one L-shaped bar or two grab bars in L-shaped configuration between 700 mm and 800 mm from the shower floor (**Figure 6.8**); and
- Have one grab bar at least 750 mm long installed vertically with another at least 900 mm long mounted horizontally.

### Stationary, Fittings and Accessories

- A shelf should be provided for toiletries between 400-800 mm
- All shower controls should be at a distance of 500 mm from the rear wall
- Shower controls should be installed between 750 mm to 1000 mm from the floor
- The adjustable and detachable shower head (telephone shower/ hand-held shower), with a minimally 1500 mm long hose, should be installed between 800 mm and 1200 mm from the floor.
- Where the shower head is mounted on a vertical bar, the bar should be installed so as not to obstruct the use of grab bars.
- Floor projection for the roll-in shower cubicle should not be more than 10 mm high or else beveled at a slope of 1:2.
- Enclosures for the shower cubicle should not obstruct transfer from wheelchair onto shower seat.

### Shower seat

- A wall mounted shower seat can be made available, preferably fold up kind.
- The shower seat should be positioned such that the distance between the centre line of the water closet and the adjacent wall is 450 mm to 480 mm, and the distance between front edge of the water closet and the rear wall is 650 mm. The top of the shower seat should be at a height of 450 - 480 mm from the floor.
- There should be an adequate clear floor space of at least 1350 mm depth and 900 mm width, both in front and on the transfer side, adjacent to the water closet.
- It may be self-draining, non-slip and with rounded edge;
- It may be on the wall nearest to the controls;
- It may have a minimum dimension of 400 mm wide extending the full depth of the cubicle, less space required for the shower curtain

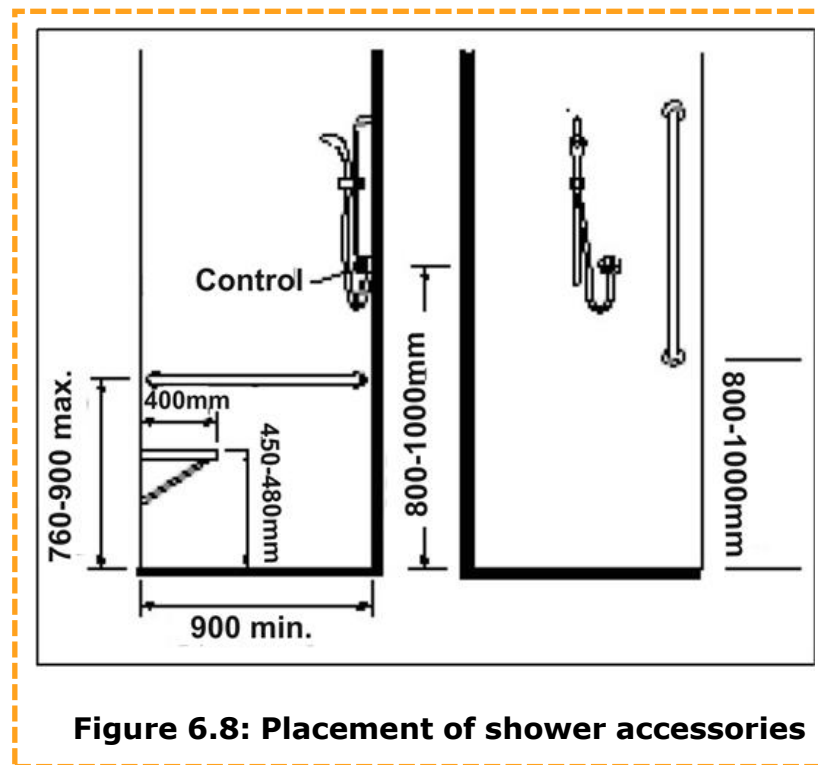

# CHAPTER 7: EMERGENCY EVACUATION IN SCHOOLS AND HOSTELS



- In all public spaces, toilets and bathrooms, visual & audio alarms to be provided to warn children in emergency situations.
- All staff and caretakers should have regular fire safety drills and sensitize children with disabilities.
- Exit areas and assembling area in an emergency & evacuation process should be part of the sensitization trainings.
- **Safety:**
  - **Boundary walls and Windows:** Provide boundary walls for buildings and grills /net on windows, open areas, balconies, terrace, etc.
  - **Residual Current Circuit Breaker (RCCB):** These should be installed in the mains electric supply to trip in case of electric shock
- **Fire Safety:**
  - **Safety Procedures:** to be provided and explained, in formats that are easily understood and take account of resident's communication needs
  - **Fire Refuge Area:** at the landing of a fire escape staircase, equipped with two-way communication gadgets with clear signage, flashing bulbs & audio signals to be provided to facilitate emergency evacuation
  - **Alarm Devices:** fire alarm boxes, emergency call buttons and lit panels should be installed between 800mm and 1000mm height from the furnished floor surface. These should be adequately contrasted from the background wall and should have embossed letters and Braille
  - Consider having audible alarms with 'voice instructions' that can help guide them to the nearest emergency exit
  - Non-auditory alarms (visual or sensory) to alert children with hearing impairments should be installed at strategic locations in all areas (including kitchen, toilet areas, etc.)
- **Evacuation Route:**
  - Evacuation routes should be clearly identified and should have signage that are strategically placed
  - Routes should be at least 1200mm wide, to ensure that a child using a wheelchair and a non-disabled child are able to pass each other along the route
  - The route should be free of any level difference and should be kept free from obstacles such as furniture, coolers, AC units, flowerpots, etc.

- Moreover, emergency exit lights in green color and directional signals mounted near the floor have been found to be useful for all people in cases where a lot of smoke is present (**Figure 7.1**)
- Use “Exit” signage along the route
- Orientation and direction signs with arrows should be installed at a height of 500mm from the floor level along the evacuation route

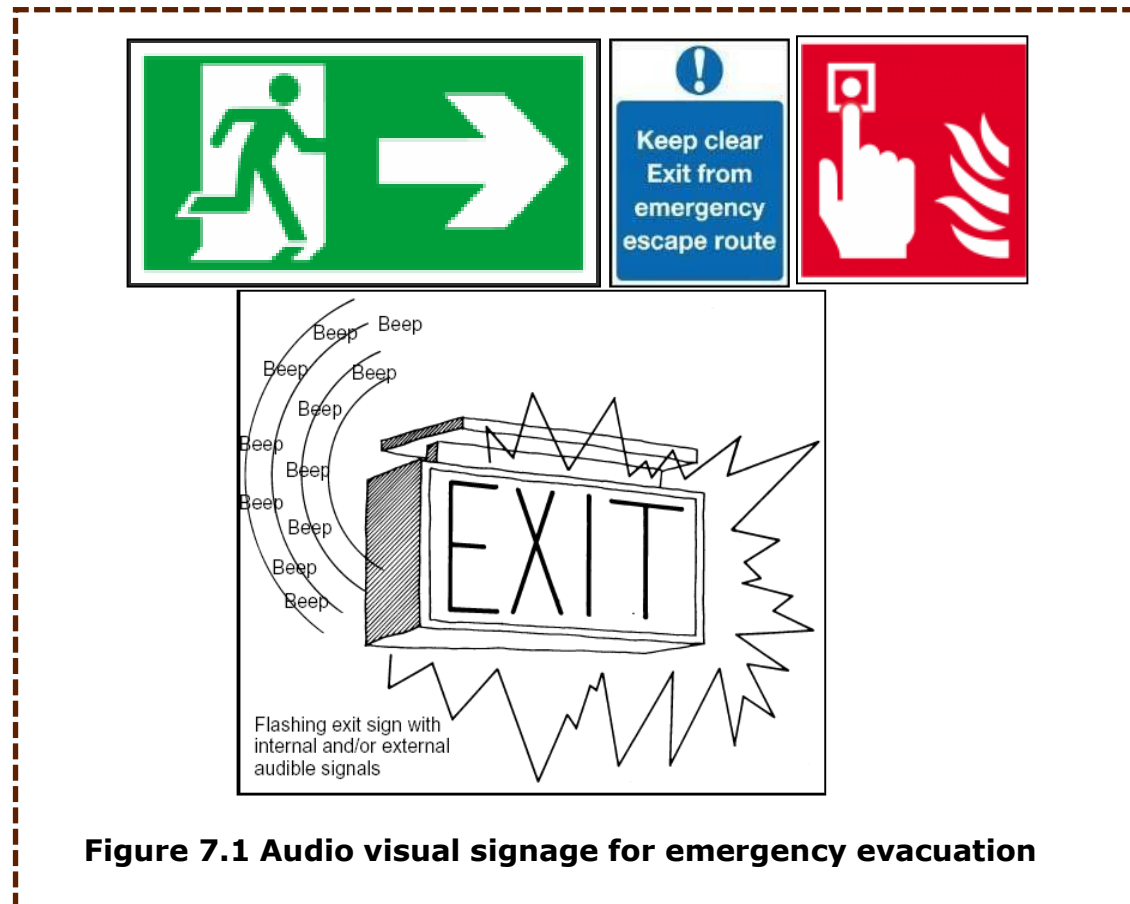

# CHAPTER 8: INFORMATION AND COMMUNICATION ACCESSIBILITY



## 8.1. Barriers and Identification of Barriers

The vision of inclusive education can be translated into action only when there is accessible communication. The barrier in communication is seen as the most critical issue that must be addressed by schools by adopting child-centred accessible communication strategies which are based on the actual needs of the learners/students. Some of the barriers in schools are listed below which hinders children with disabilities to derive benefits from education. Some common barriers to effective communication in the classroom are listening barriers, perception barriers, oral barriers and cultural barriers. Learning to recognize and overcome these barriers is essential in effective classroom communication.

### 8.1.1 Identification of Barriers

Some of the barriers in schools are listed below that hinder children with disabilities from benefiting from education.

Disabilities	Barrier	Solutions
Visual Impairment	<ul style="list-style-type: none"> <li>• Small print or no large-print versions</li> <li>• Videos</li> <li>• Charts</li> <li>• Maps graphs</li> <li>• Inaccessible e-contents and digital materials</li> </ul>	<ul style="list-style-type: none"> <li>• Braille</li> <li>• Screen Reader and contents compatible with screen reader software</li> <li>• Colour Contrast</li> <li>• Voice recorders_</li> <li>• Tactile maps, graphs and diagrams</li> <li>• Availability of printers for tactile printouts</li> <li>• Podcast</li> <li>• Signage (braille)</li> <li>• Augmentative and alternative communication</li> <li>• Large Print</li> <li>• DAISY book (Full text and auto synchronized)</li> <li>• Braille Formatted File (BRF)</li> <li>• Digital book</li> </ul>

		<ul style="list-style-type: none"> <li>• Visuals with audio descriptions, downloadable</li> </ul>
Hearing Impairments	<ul style="list-style-type: none"> <li>• Oral Communication</li> <li>• Videos without caption</li> </ul>	<ul style="list-style-type: none"> <li>• Sign language</li> <li>• PEC (Picture Exchange Communication)</li> <li>• Signage</li> <li>• Written instructions</li> <li>• Visuals with closed captioning and Indian Sign Language, downloadable materials like EPUB (text only), Easy to read format, etc</li> </ul>
Cognitive Impairment	<ul style="list-style-type: none"> <li>• Long sentences, words, pace, Technical Language</li> <li>• Abstract contents, longer contents, clutter contents</li> </ul>	<ul style="list-style-type: none"> <li>• Simplified Language</li> <li>• Graphic organizers</li> <li>• Voice recorder</li> <li>• Podcast</li> <li>• Visual schedule</li> <li>• Concrete presentations or concretization of abstract concepts</li> <li>• Multi-sensorial media and models</li> <li>• Multimodal representation of content with visual (Images, videos)</li> <li>• Auditory feedback</li> <li>• Online interactive materials, offline and downloadable materials</li> <li>• Manipulative materials, devices, equipment, Objects, activity schedule and sequence</li> <li>• Simple and unambiguous language text, abbreviations expanded, jargon avoided, clear purpose and meaning to context</li> <li>• Animation and images / pictures, small segmented, interactive materials, color codes and contrasts</li> </ul>



<p>Locomotor disabilities</p>	<ul style="list-style-type: none"> <li>• Thin pages book, stapled book</li> <li>• Computer keyboard and accessories</li> <li>• Inaccessible software</li> <li>• Verbal communication</li> <li>• Communication using sign, gestures, etc (due to perceptual motor difficulties)</li> <li>• Lab equipment having finer adjustment like microscope, reading clock, geometry kit, ordinary pen</li> </ul>	<ul style="list-style-type: none"> <li>• Graded paged book, spiral book</li> <li>• Adapted hardware assistive technological equipment</li> <li>• Adapted computer software (eg. Text to speech, visual scan to speech, etc)</li> <li>• Alternative and augmentative communication</li> <li>• Picture exchange communication system</li> <li>• Adapted lab equipment, measuring scale, geometry kit, adapted writing board etc</li> </ul>
-------------------------------	---	--

## 8.2. Accessibility Standards

Accessible communication benefits all by making information clear, direct and easy to understand. School must provide or organize accessible formats and communication supports when providing information to persons with disabilities. Accessible formats of communication are also known as alternative formats of communication, which are means and formats of communication, languages, display of text, Braille, Tactile communication, signs, large prints, accessible multimedia, written, audio, video, visual displays, sign language, plain-language, human-reader, augmentative and alternate modes and accessible

information and communication technology for people with different disabilities and people using oral-aural, sign, tactile digital mode of communication.

For Instance accessible format include:

Disability and Inaccessible format	Accessible Format/Standards
<p>Visual Disability (Preferring aural and tactile mode for information and communication)</p> <ul style="list-style-type: none"> <li>• Print</li> <li>• Written materials</li> <li>• Visual materials</li> <li>• Digital text and images</li> </ul>	<ul style="list-style-type: none"> <li>• Contents in Braille</li> <li>• Large print</li> <li>• Colour Contrast /Dark theme</li> <li>• Accessible digital files, such as:               <ul style="list-style-type: none"> <li>○ Html</li> <li>○ Microsoft Word available as per WCAG 2.0 guidelines</li> </ul> </li> <li>• Audio description</li> <li>• Accessible Digital text using screen reader / screen magnifier, Braille display, large monitor, DAISY materials</li> </ul>
<p>Hearing Disability (Preferring visual mode for information and communication)</p> <p>Oral / verbal contents Aural (audio) materials</p>	<ul style="list-style-type: none"> <li>• Contents in sign language</li> <li>• Contents interpreted through Sign Language</li> <li>• Audio-visual materials with closed captioning and sign language</li> <li>• Visual description</li> <li>• Assistive listening systems</li> <li>• Augmentative or alternative communication devices, including:</li> </ul>

	<ul style="list-style-type: none"> <li>• Letter, word, or picture boards</li> <li>• <b>Communication</b> Devices that convert text to speech <b>for communication with others</b></li> <li>• Reading aloud</li> <li>• Rephrasing in clear language</li> <li>• <b>Lab and Other equipment with sound and visible signals</b></li> <li>• <b>Print text/document to Digital Accessible Information System (DAISY) files for audio output for others</b></li> </ul>
Locomotor Disability (Prefer visual and oral - aural mode of information and communication)	As in 8.1.1

Finally, other requirements in the Information and Communications Standards apply to schools and libraries. For example, schools and school boards must provide [accessibility awareness training for educators](#). Likewise, organizations that produce educational resources must [make those resources accessible](#). Similarly, [school libraries](#) and [public libraries](#) must procure accessible versions of print, digital, and multimedia resources

## **ANNEXURE I**

### **ACCESSIBILITY AUDIT CHECKLIST**

To carry out an accessibility audit of the schools, an accessibility audit checklist is required. The purpose of an accessibility audit is to carry out a detailed appraisal of the accessibility of the physical infrastructure, services and facilities of the school campus. Accessibility audits are not a new concept, and the Accessible India Campaign mandates accessibility audit of existing buildings and vetting of plans of upcoming/ new constructions. Accessibility audit is carried out by School Management Committees, Parents, Accessibility Auditors (accredited by the Government of India) and specialist's viz. architects, occupational therapists, engineers and organizations of persons with disability

### **WHAT IS AN ACCESSIBILITY AUDIT CHECKLIST?**

Accessibility audit checklist is one of the tools to assess and make recommendations regarding the level of accessibility (approach to and within the building and use of all services and facilities). The checklist gives access requirements to comply with the needs of diverse user groups.

### **HOW TO USE THE CHECKLIST?**

The checklist should be used for existing amenities and identifying barriers in the school premises, in terms of Physical Environment and Information and Communication accessibility. It can be used for monitoring and maintenance purpose. It helps to ensure that all retrofitting work and new construction comply with essential access standards.

### **PRE-ACCESS AUDIT SELF ASSESSMENT CHECKLIST**

This checklist helps in self-assessment and can be used as a tool to bring about attitudinal change and achieve overall inclusion. The checklist is commonly used for advocacy, raising awareness and audits by third party for making schools accessible and barrier free. It is also important to be aware that an accessibility audit can be carried out by anyone who is responsible for school maintenance and use. SMCs and parents can conduct self-assessment to evaluate existing elements and upgrade these to make the school accessible to all its users. This means that for self-assessment and scaling up, the accessibility of school services should also be considered. The checklist is given in section 8.4.1.

### Self-Assessment Checklist

S. No.	Particulars	Remarks
1	<b>Name of the school</b>	
2	<b>Date</b>	
3	<b>Focal person with contact details</b>	
4	<b>Total student's strength</b>	
	Boys	
	Girls	
	CWSN – Boys	
	CWSN – Girls	
5	<b>Total staff strength</b>	
	Teaching/non-teaching	
	Special educator (if any)	
6	<b>Teaching/non-teaching staff with disabilities (if any)</b>	

## Physical Environment Checklist (Part I)

<b>EXTERNAL ENVIRONMENT</b>	<b>Yes</b>	<b>No</b>	<b>Remarks</b>
<b>Pedestrian Crossings</b>			
Are traffic lights installed with auditory signals?			
Is zebra crossing provided?			
If zebra crossing is provided, is it embossed so that it is detectable with a white cane?			
<b>Footpaths</b>			
	<b>Yes</b>	<b>No</b>	<b>Remarks</b>
Is the footpath clear of all obstructions?			
Is the surface leveled, firm, smooth and non-slippery?			
Is the footpath width adequate for two wheelchairs to cross?			
Are all manholes placed outside the pedestrian path of travel?			
If not, are the manhole covers properly secured and flushed properly?			

<b>Kerb Ramp (ramp for footpath)</b>			
Are kerb ramps provided at level differences, between the road surface and kerb/footpath height?			
Are kerb ramps provided at pedestrian crossings?			
Are kerb ramp provided near the school entrance?			
<b>General Obstructions</b>			
Are there any protruding objects in the path of travel, not detectable by a person with visual impairment using white cane?			
<b>Main Gate</b>			
Is the surface level firm, smooth and non-slippery?			
Is the main gate guarded by security?			
Is there a separate accessible gate for pedestrian entry/exit?			
<b>Building Entrances- Ramp</b>			
Are there ramps provided?			
Are there continuous handrails on both sides of ramp?			
Is the gradient of the ramp 1:15?			
Is the minimum width of ramp 1200mm (4 ft)?			

Is there a landing provided at every turning?			
Is the surface of the ramp smooth and non-slippery/anti-skid?			
Is there edge protection on both sides of the ramp?			
<b>Steps</b>			
Is the step riser not more than 150mm?			
Is the staircase width more than 1800mm (6 ft)?			
Are there continuous handrails on both sides of staircase?			
Are there handrails painted in contrast color?			
Is there an open area (soffit) under the staircase, which is unguarded?			
Do the steps have nosing (protruding edge)?			
<b>Handrails</b>			
Are the handrails continuous, on steps and ramp even on landings?			
Can a child with disability easily grab the handrail?			
Are there handrails painted in contrast color?			
<b>Doors</b>			
Can the doors be operated without much effort?			





Is manual door accessories/hardware (handles, locks, pull etc.) located at a reachable height?			
Are doormats flushed with the floor surface and all edges of the doormat secured to the floor?			
Is the threshold (doorsill) high and beveled (merged with gentle slope)?			
<b>Corridors</b>			
Is the surface of Corridor firm and smooth with antiskid surface?			
Can a person with vision impairment detect all protruding objects within the corridor?			
Is there overhead clearance provided while mounting hanging obstructions?			
<b>Signage</b>			
Are there signage for classroom, library and all other amenities provided?			
Are these signages in contrast color so that it is easily readable by a child with low vision?			
Are classroom signages provided on the wall at eye level?			
Are there signage provided for girl's and boy's toilet?			
Are there signage provided for girls and boys accessible (CWDS) toilet?			
Are there signages for emergency evacuation?			



<b>Classrooms</b>			
Are the classrooms no. and names (if any) given in Braille also?			
Are there tactile cues (warning paver) marking the location to the Braille signage?			
Is the entry to the classroom free of any level difference?			
Is the illumination level in the classroom adequate for a child with low vision?			
Is there a white light source (tube-light/CFL) above the teacher for lip reading by children with hearing impairments?			
Are the furniture in the classroom suitable to the child height?			
Are there adapted furniture for a CwDs- CP chair, separate desk and table, etc.?			
<b>Library/Labs</b>			
Is there ample maneuvering space between the book almirahs in library?			
Are the tables and lab equipment accessible for wheelchair users?			
<b>Toilets</b>			
Is there separate toilet for girls and boys?			
Are there separate accessible (CwDs) toilets for boys and girls?			
Are these toilets near the classroom block?			

Are there signage (symbol of male and female) provided for identification of toilets?			
Are these toilets have roof/ covered urinals, piped water and hand washing spaces?			
Are there incinerator provided for menstruation hygiene menstruation for girl's toilets?			
<b>Drinking Water</b>			
Is there RO/ filtered drinking water available for children?			
Is the water available directly from the RO or stored in a container?			
Is there drainage and washbasin provided?			



## External Environment Upcoming & New Constructions (Part II)



This checklist is mandatory for all upcoming and new constructions. This is easy to use checklist by accessibility auditors/ professionals/ architects/ engineers, etc. who are planning, designing, constructing or auditing the educational institutions.

EXTERNAL ENVIRONMENT				
Pedestrian Crossings	Yes	No	Remarks	
Is there speed limit signage to orient the vehicle drivers?				
Is there 'school ahead' signage, 50m before school main gate and on both sides of road?				 <p>USE OF TACTILE SURFACING AT A TRAFFIC ISLAND</p> <p>Tactile paving</p>

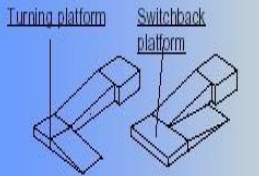
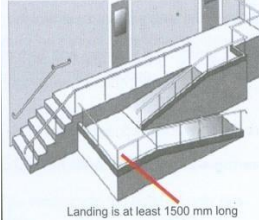

<b>Footpaths</b>	<b>Yes</b>	<b>No</b>	<b>Remarks</b>	
Is the footpath clear of all obstructions?				
Is the footpath at least 1800mm wide?				
Is the surface level, smooth and non-slippery?				
Are all manholes' places outside the pedestrian path of travel?				
<b>Kerb Ramps (ramp for footpath)</b>	<b>Yes</b>	<b>No</b>	<b>Remarks</b>	
Are kerb ramps provided at all level differences, between the road surface and footpath level:				
a) At Pedestrian crossings?				
b) At Accessible parking space?				
c) At Building entrances?				
<b>General</b>	<b>Yes</b>	<b>No</b>	<b>Remarks</b>	
Are there any protruding objects while approaching the school, which is not detectable by a child with visual impairment using white cane?				
Is there a boundary wall provided compounding the school campus?				

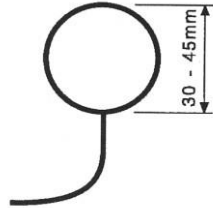
Parking	Yes	No	Remarks	
Is the parking inside /outside the premises?				
Is the parking within 30 meters of the accessible entrance?				
Is the parking space adequate for cycles, two-wheelers, tricycles, and any other vehicle?				
Do parked vehicles outside the gate obstruct footpaths/ pedestrian areas?				
Is there a vertical, visible signboard indicating accessible parking spaces for use by CwDS and persons with disabilities?				
If yes, is the size of the parking 3600mm x 5000mm?				
<b>INTERNAL ENVIRONMENT</b>				
Ramps	Yes	No	Remarks	
Is there a ramp next to the stairs?				
Is the location of the ramp clearly identifiable?				
Is the ramp gradient no steeper than 1:15?				
Is the minimum width of the ramp 1800mm (2m preferred)?				
Are there continuous handrails, on both sides, at a height between 760mm-900mm?				

Is the surface of the ramp anti-slip/ matt finish?				
Is there an edge protection on both sides of the ramp?				
<b>Steps/Stairs</b>	<b>Yes</b>	<b>No</b>	<b>Remarks</b>	
Is the location of the steps easily identifiable?				
Is the minimum width of the stairs 1200mm?				
Are there continuous handrails, on both sides, at a height between 760mm-900mm?				
Do the stairs have a nosing?				
Are the step edges of a different colour or texture easily identifiable by child with visual impairment?				
Is the location of emergency (fire escape) stairs clearly identifiable?				
Are the risers having open gaps in the steps?				

Is the step riser not more than 150mm?				
Is there an open space under staircase which is not guarded?				
<b>Handrails</b>	<b>Yes</b>	<b>No</b>	<b>Remarks</b>	
Are handrails mounted at two levels- height 760mm and 900mm?				
Are handrails easy to grip (diameter 38mm preferred)?				
Are the handrails painted in contrast colours to be easily identifiable?				
<b>General Toilets</b>	<b>Yes</b>	<b>No</b>	<b>Remarks</b>	
Is there signage provided for girls and boys toilet?				
Is there Braille signage provided at height of 1000 and 1400mm for each toilet?				

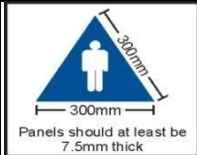
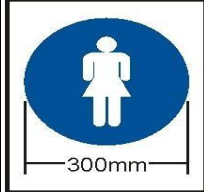



Is there latch inside girl's toilet at two levels 400mm and 800mm height?				 
Is there adequate illumination in both the toilets?				
Is there incinerator available in girl's toilet?				
Is there piped water facility available in girl's toilet?				
<b>Accessible Toilets</b>	<b>Yes</b>	<b>No</b>	<b>Remarks</b>	
Are there separate accessible toilets for children with disabilities (preferred separate accessible toilet for girls and boys)?				 
Are these toilets within 30m of the classroom/s block?				
Is there signage provided for girls and boys accessible toilet?				
Is the size of the toilet minimum 2000mm x 2200mm?				
Is there sufficient wheelchair manoeuvring space of 1500 x 1500mm around the WC and washbasin?				
Is the washbasin mounted at a height between 700mm-800mm?				
Is the lower edge of the mirror positioned at a height of 1000mm?				
Are there transfers garb bars installed near WC?				

Are all the grab bars at a height between 700mm-800mm?				
Is the toilet equipped with an emergency alarm system?				
Can doors be locked from inside and releasable from outside under emergency situations?				
Are flushing equipment easy to operate?				
Is the floor material skid proof, well drained and waterproof?				
Is the WC (western commode seat) height at 300- 400mm (child height)?				
Is the tap height at 800mm max.?				
Is the toilet door minimum 900mm wide and open outwards?				
Is the ramp gradient- 1:15?				
Is there landing of 1500mm x 1500mm provided at turning of the ramp?				
Are there handrails on both sides of the ramp?				
Is the toilet equipped with an emergency alarm system?				
Can the doors be locked from the inside and unlocked from outside in emergency situations?				
Is there an incinerator or dustbin available for disposal of sanitary				

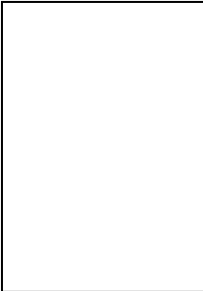
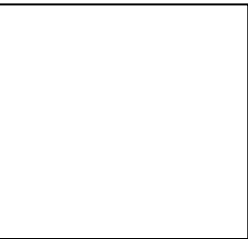

pads?				
<b>Lift</b>	<b>Yes</b>	<b>No</b>	<b>Remarks</b>	
Is the school building more than 2 floors?				
Is ramp provided alongside staircase to access the upper floors?				
If ramp is not provided, is there provision of a lift?				
Is the minimum size of the lift 1.5m x 1.5m?				
Is the call button not above 800mm?				
Is the control panel between 400-1200mm?				
Is there Braille and embossed impression on call and control panels buttons?				
Are there handrails/ grab bars inside the lift?				
Is there a mirror in the lift car on wall opposite to door to serve as rear view mirror?				
Is there audio announcement when lift is operated- floor nos., door opening/ closing announcement?				

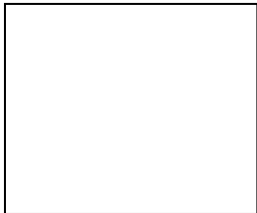
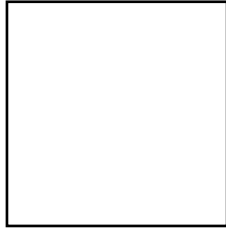

Is the lift manned for safety of the children?				
Is there emergency backup of lift operations?				
Will the lift stop at immediate next floor in case of emergency (for example fire)?				
<b>Doors</b>	<b>Yes</b>	<b>No</b>	<b>Remarks</b>	
Can the doors be operated without much effort?				
Is manual door accessories/hardware (handles, locks, pull etc.) located at a reachable height?				
Are doormats flushed with the floor surface and all edges of the doormat secured to the floor?				
Is the threshold (doorsill) high and beveled (merged with gentle slope)?				
<b>Corridors</b>	<b>Yes</b>	<b>No</b>	<b>Remarks</b>	
Is the surface of corridor firm and smooth with antiskid surface?				
Can a person with vision impairment detect all protruding objects within the corridor?				
Is there overhead clearance provided while mounting hanging obstructions?				

Signage	Yes	No	Remarks	
Are there signage for classroom, library and all other amenities provided?				
Are these signages in contrast color so that it is easily readable by a child with low vision?				
Are classroom signages provided in Braille and on the wall at eye level?				
Classrooms	Yes	No	Remarks	
Is the entry to the classroom free of any level difference?				
Is the illumination level in the classroom adequate for a child with low vision?				
Is there a white light source (tube-light/CFL) above the teacher for lip reading by children with hearing impairments?				
Are the furniture in the classroom suitable to the child height?				
Are there adapted furniture for CwDs?				
Is the green board height not above 500mm from floor level?				
Are there two doors for each classroom for ease of emergency evacuation?				
Is there a visual and audio emergency alarm system installed in each				

classroom?				
<b>Library/Labs</b>	<b>Yes</b>	<b>No</b>	<b>Remarks</b>	
Is there ample maneuvering space between the book almirahs in library?				
Are the tables and lab equipment accessible for wheelchair users?				
Are the labels on book stacks marked in big fonts and contrast colour?				
Is the labels height not above 1m from floor level?				
Is there 900mm clear space between stacking for assistive device users to maneuver around?				
Is the library and other staff manning the counters available for providing the books on request?				
<b>Drinking water</b>	<b>Yes</b>	<b>No</b>	<b>Remarks</b>	
Is there RO/ filtered drinking water available for children?				
Is the water available directly from the RO or stored in a container?				
Is there drainage and washbasin provided?				
Is there signage of drinking water given to identify its location?				

Emergencies	Yes	No	Remarks	
Are emergency exits clearly marked with directional arrow signs?				
Does school campus have emergency alarm with both audio (hooter type) and visual flashing bulb?				
Do hostel accessible rooms, common room and dining area have both audio (hooter type) and visual flashing bulb?				
Do the students/hostel residents with disabilities undergo mock drill for emergency evacuation?				
Playground	Yes	No	Remarks	
Is there a paved pathway leading to the playing area?				
Are there seating benches around playground?				
Are there playing equipment's which can be used by children with disabilities also?				
Mid-Day Meal	Yes	No	Remarks	
Is the mid-day meal area accessible to children with disabilities?				

Is there a circulation path of at least 900mm wide to allow a wheelchair user to move around the eating area?			
Is a table provided for children with disabilities using wheelchairs/ wearing calipers?			
Is the table accessible – having height of 800mm and knee space of 750mm wide and 480mm deep?			
Are the table corners rounded off to safeguard children from hitting these?			
Does the table with fixed stools have accessible spaces for wheelchairs?			
Are the table and fixed stools edges marked in contrast colour for ease of children with low vision?			

### Information & Communication (Part III)

To carry out an accessibility audit of the school, an accessibility checklist is required. Accessibility audit is carried out by School Management Committees, Parents, Accessibility Auditors and organizations of persons with disabilities.

S.no	Questions	Yes	No	Remarks or Recommendation
1. (a)	The website provides information about the building/service complies with web accessibility standards			



<b>(b)</b>	There is information detailing the accessible facilities in the building with photographs			
<b>2.</b>	<p>All publications/brochures are available is also available in alternate accessible formats such as: -</p> <ul style="list-style-type: none"> <li>* Braille</li> <li>* Large Print</li> <li>* Audio</li> <li>* Pictorial(wherever possible)</li> <li>* Easy-to-read</li> <li>* Plain language</li> <li>* Available in Hindi&amp; English</li> <li>* Accessible Electronic formats that can be shared over email or mobile platforms.</li> </ul>			
<b>3.</b>	Printed service-related documents such as forms, rules and regulation etc. are in accessible formats			

4.	School websites follows the guidelines of WCAG(web content accessibility guidelines)			
5.	Forms can be filed electronically through an accessible software			
6.	Additional support is available to fill in written forms if required.			
7.	Staff members are trained in Indian Sign Language interpretation. If not, then Sign language interpreters are available on call.			
8.	Assistive technology such as Loop hearing systems, Audio orientation tools, interpretative videos or audio tours in with captioning or sign language, wheelchairs etc. are available			
9.	There is adequate lighting and no glare for deaf			

	persons and persons with low vision			
<b>10.</b>	Adequate support is available for persons from different cultures, learning disabilities, those not formally educated, in all the above provisions			

## ANNEXURE II

### Creation of Accessible Website

**WCAG** is the most-referenced set of **standards** in website accessibility lawsuits and is widely considered the best way to achieve accessibility. School websites/social media/e content on internet/digital learning materials must follow WCAG.

Guideline	Summary
<a href="#">1.2.4 – Captions (Live)</a>	Add captions to live videos.
<a href="#">1.2.5 – Audio Description (Pre-recorded)</a>	Provide audio descriptions for pre-recorded videos.
<a href="#">1.3.4 – Orientation</a>	Your website adapts to portrait and landscape views.
<a href="#">1.3.5 – Identify Input Purpose</a>	The purpose of input fields must be programmatically determinable.
<a href="#">1.4.3 – Contrast (Minimum)</a>	The contrast ratio between text and background is at least 4.5:1.
<a href="#">1.4.4 – Resize Text</a>	Text can be resized to 200% without loss of content or function.
<a href="#">1.4.5 – Images of Text</a>	Don't use images of text.
<a href="#">1.4.10 – Reflow</a>	Content retains meaning and function without scrolling in two dimensions.
<a href="#">1.4.11 – Non-Text Contrast</a>	The contrast between user interface components, graphics and adjacent colours is at least 3:1.
<a href="#">1.4.12 – Text Spacing</a>	Content and function retain meaning when users change elements of text spacing.
<a href="#">1.4.13 – Content on Hover or Focus</a>	When hover or focus triggers content to appear, it is dismissible, hoverable and persistent.

[2.4.5 – Multiple Ways](#)

Offer at least two ways to find pages on your website.

[2.4.6 – Headings and Labels](#)

Headings and labels describe the topic or purpose.

[3.1.2 – Language of Parts](#)

Tell users when the language on a page changes

[3.2.3 – Consistent Navigation](#)

Use menus consistently

[3.2.4 – Consistent Identification](#)

Use icons and buttons consistently

[3.3.3 – Error Suggestion](#)

Suggest fixes when users make errors

[3.3.4- Error Prevention \(Legal, Financial, Data\)](#)

Reduce the risk of input errors for sensitive data

## **WCAG Checklist Level AAA (Advanced)**

### **Guideline**

### **Summary**

[1.2.6 – Sign Language \(Pre-recorded\)](#)

Provide sign language translations for pre-recorded videos.

[1.2.7 – Extended Audio description \(Pre-recorded\)](#)

Provide extended audio descriptions for pre-recorded videos.

[1.2.8 – Media Alternative \(Pre-recorded\)](#)

Provide text alternatives for pre-recorded videos.

[1.2.9 – Audio Only \(Live\)](#)

Provide alternatives for live audio.

[1.3.6 – Identify Purpose](#)

The purpose of all components must be programmatically determinable.

[1.4.6 – Contrast \(Enhanced\)](#)

The contrast ratio between text and background is at least 7:1.

[1.4.7 – Low or No Background Audio](#)

Audio-only content is clear with no or minimal background noise.

[1.4.8 – Visual Presentation](#)

Offer users a range of presentation options for blocks of text.

[1.4.9 – Images of Text \(No Exception\)](#)

Don't use images of text.

[2.1.3 – Keyboard \(No Exception\)](#)

All functionality is accessible by keyboard with no exceptions.

[2.2.3 – No Timing](#)

No time limits on your website.

[2.2.4 – Interruptions](#)

Users can postpone or suppress non-emergency interruptions.

[2.2.5 – Re-authenticating](#)

Save user data when re-authenticating.

[2.2.6 – Timeouts](#)

Warn users about timeouts that cause data loss.

[2.3.2 – Three Flashes](#)

No content flashes more than three times per second.

[2.3.3 – Animation from Interactions](#)

Users can disable motion animation.

[2.4.8 – Location](#)

Let users know where they are on your website.

[2.4.9 – Link Purpose \(Link Only\)](#)

Every link's purpose is clear from its text.

[2.4.10 – Section Headings](#)

Organise content with headings.

[3.1.3 – Unusual words](#)

Explain any strange words

[3.1.4 – Abbreviations](#)

Explain any abbreviations

[3.1.5 – Reading Level](#)

Users with nine years of school can read your content

[3.1.6 – Pronunciation](#)

Explain any words that are hard to pronounce

[3.2.5 – Change on Request](#)

Don't change elements on your website until users ask

[3.3.5 – Help](#)

Provide detailed help and instructions

[3.3.6 – Error Prevention \(All\)](#)

Reduce the risk of all input errors

## GLOSSARY

### **Access Aisle**

An accessible pedestrian space between elements, such as parking spaces, seating and desks that provides clearances appropriate for use of elements.

### **Accessible**

A site, building, facility, or portion thereof that complies with this manual and that can be approached, entered and used by persons with disabilities.

### **Accessible Route**

A continuous unobstructed path connecting all accessible elements and spaces in a building that can be used and negotiated by a person with disability using a mobility aid.

- Interior accessible routes may include corridors, ramps, lifts and floor space.
- Exterior accessible routes may include parking, access aisles, kerb ramps, walkways and ramps.

### **Accessible Toilet**

Toilet cubicle accessible to mobility aid users especially wheelchair users and having western water closet seat, washbasin and grab bars.

### **Beveled**

Smooth, slanted angle between two surfaces; for example, a slope or inclination between two uneven surfaces to allow easier passage of a wheelchair or other mobility aids.

### **Braille**

The Braille system is a method that is widely used by blind people to read and write. Each Braille character or cell is made up of six dot positions, arranged in a rectangle containing two columns of three dots each. Braille is adapted to several languages including Hindi. Braille comprises of two grades – Grade 1 & Grade 2

## Circulation Path

An exterior or interior way of passage from one place to another for pedestrians, including walkways, hallways, courtyards, stairways, and stair landings.

## Clear Door Width

The clear door width is the unobstructed passage available after decreasing the 1) thickness of the door; 2) the space between the door and the frame on the hinged side; and 3) the thickness of doorstop molding on the doorframe. Therefore, the clear door width is always less than the full width of the door.

## Colour Contrast

The basic guidelines for making effective colour choices are based on the hue value of the colours. The most commonly used methods of achieving colour contrast incorporate either 'harmonizing' or 'contrasting' colour combinations.

## Fixed Turning Wheel Radius

The track of the caster wheels and large wheels of a wheelchair when pivoting on a spot.

## Grab Bar

A bar used to give a steadying or stabilizing assistance to a person engaged in a particular function.

## Handrail

A rail used in circulation areas such as corridors, passageways, ramps and stairways to assist in continuous movement.

## International Symbol of Access

The symbol denotes a barrier free environment, which also helps elderly people, parents with prams, and travelers with luggage.

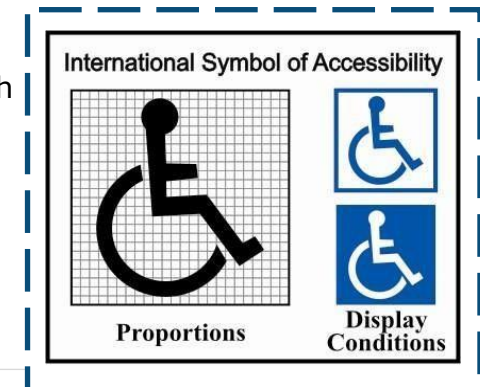



### **Kerb Ramp**

A short ramp cutting through a kerb or built up to it.

### **Operable Parts**

A part of a piece of equipment or appliance used to insert or withdraw objects, or to activate, deactivate, or adjust the equipment/ appliance (for example light switch, pushbutton, handle).

### **Ramp**

An inclined way connecting one level with another.

### **Tactile**

That can be perceived using the sense of touch.

### **Tactile Guiding Pavers/ Block**

These flat-topped bars are easily detectable underfoot by persons with visual impairment. They are used externally to guide them along the circulation path.

### **Tactile Warning Pavers/Block**

These are used in order to warn persons with visual impairment.

## References

- 1) Accessibility Research and Comparative Analysis of Building Standards & Regulations in various states of India, Anjlee Agarwal, 2011
- 2) Accessible Signage Guidelines, Institute of Access Training Australia, 2012
- 3) Code of practice for road signs, IRC: 67-2010
- 4) Color standards for general purposes: AS 2700:1996
- 5) Design for Access and Mobility Enhanced and Additional Requirements - Buildings and Facilities: AS 1428.2:1992
- 6) Design for access and mobility General Requirements for Access – New Building Work: AS 1428.1:2009
- 7) Emergency escape lighting and exit signs for buildings – System design, installation and operation: AS 2293.1:2005
- 8) Fire detection, warning control and intercom systems – System design, installation and commissioning – Sound systems and intercom systems for emergency purposes: AS 1670.4:2004
- 9) Graphical symbols – Public information symbols: ISO 7001:2007
- 10) Guidelines on BFE-Schools, Samarthyam, 2014
- 11) Harmonised Guidelines and Space Standards for Barrier Free Built Environment for Persons with Disabilities and Elderly, Ministry of Urban Affairs and Housing, Government of India
- 12) Inclusive Mobility, UK
- 13) Interior lighting - Safe movement: AS /NZS 1680.0:1998
- 14) IRC 103: 2012, Guidelines Pedestrian Facilities, Indian Roads Congress, 2012
- 15) ISOMA, <http://www.isemoa.eu/>
- 16) IUT Codes- Signage, Intersections, Road Marking, Cross Section and Traffic Calming
- 17) Lifts, escalators and moving walks – General requirements: AS 1735.1:2003
- 18) Making Schools Accessible to Children with Disabilities, UNCEF, Ministry of Social Justice & Empowerment & Samarthyam, 2016
- 19) National Building Code, 2016
- 20) ORN 21, DFID, UK
- 21) Public Transport Accessibility Toolkit, 2013, MoUD and IUT
- 22) Space Standards for Barrier Free Built Environment for Disabled and Elderly Persons, 1998, Ministry of Urban Development, Government of India
- 23) Street Design Guidelines, UTTIPEC
- 24) United Nations Convention on Rights of Persons with Disabilities (UNCRPD)
- 25) Wayfinding Design Guidelines, CRC, 2007
- 26) The illustrations and graphics are created by Samarthyam

